

CAT-200B Repeater Controller

Computer Automation Technology, Inc.

4631 N.W. 31st Avenue, Suite 142
Fort Lauderdale, Florida 33309
Phone: (954) 978-6171 Fax: (561) 488-2894
Internet: <http://www.catauto.com>

Table of Contents

Chapter		Page
1.	Introduction and Specifications	1-1
2.	System Configuration	2-1
3.	Repeater Control (DTMF)	3-1
4.	Repeater Operation	4-1
5.	Repeater Programming (DTMF)	5-1
6.	Interfacing to Other Equipment	6-1
7.	Weather Station Interface	7-1
8.	Vocabulary Word List	8-1
9.	Drawings	9-1
10.	Schematics	10-1
11.	Parts List	11-1
12.	Remote Transceiver Weather Station	12-1
13.	CI-200 Interface Module	13-1
14.	DL-1000C Audio Delay Module	14-1
15.	RLS-1000B Remote Link Switch	15-1

REVISED 10/15/04 (V1.13C)

Chapter 1 - Introduction and Specifications

Congratulations on your purchase of the CAT-200B Repeater Controller. Programming the CAT-200B is a snap, with its carefully structured uniform programming commands. The manual is easy to follow and the voice synthesizer interacts with you during control and programming operation.

Voice Synthesizer

A vocabulary base of 335 words is available to ID your repeater and make voice announcements.

CW ID

The controller will switch to CW when a repeater user talks over the voice ID. When the voice ID, message #1 is erased, the controller will ID in CW only.

Courtesy Tone

Separate courtesy tones denote repeater and link receiver activity.

Link Control

The CAT-200B will support a link transceiver. You can enable the transceiver or just the receiver to monitor activity on the transceiver frequency while you use the repeater. The CAT-200B will suppress your repeater identification from being transmitted on the transceiver frequency if Zone 2 Channel 5 is disabled.

Weather Station Interface

Provide timely weather announcements on your repeater system. Connect a Peet Brothers Ultimeter ® U-100, U-800 or U-2000 Weather Station to the serial port of the CAT-200B. Integrate temperature, wind speed, direction and rainfall into any of the CAT-200B voice messages. Program a special weather report message as part of your identification.

Beacon Mode

When the repeater is inactive and Zone 4 Channel 2 is enabled, the CAT-200B will key the transmitter and announce voice message 7. This message will repeat at a rate determined by the Beacon timer.

User Function Output Switches

Four open collector user function output switches control equipment at your repeater site. These switches are controlled manually by DTMF commands or from within a voice message. They can be made to turn OFF, ON or Momentarily change state, any time you choose.

User Function Inputs

Four inputs activated by a voltage change from other equipment at the repeater site, causes the CAT-200B to activate voice messages as alarms or announcements. The messages will continue to repeat as long as the respective logic input remains active high. The logic input message timer controls the time between announcements. Information about the repeater site will be instantly available.

DTMF Keypad Test

A DTMF keypad test will read back the numbers decoded in a synthesized voice.

Specifications

Microprocessor	P80C51RD2
Memory	25C320
Voice Synthesizer	Texas Instruments MSP53C391NI2D
Voice Vocabulary	335 Words
DTMF Receiver	MT8870
Operating Temperature	-15 to +55 degrees C
Call Letter ID	Buffer size VOICE (15) - CW (16)
User Function Outputs	(4) Switch 40VDC @ 50mA.
Logic Inputs	(4) 10K ohm input impedance
	Low (0 to 0.8VDC) High (2.4 to 15VDC)
Logic Outputs	Open Collector Relay Driver (28VDC at 50mA)
Audio Input	Receiver 0.2 - 2VAC adjustable 10K ohms
Audio Output	Transmitter 2VAC adjustable 600 ohms
Power	+9 to +15VDC at 70mA
Size	4.5" X 5.0"
Warranty	Limited one year, parts and labor.

FCC Part 15 RF Interference

When installed in the RME-200 rack mount enclosure, the CAT-200B has been tested and found to meet the standards for a Class A digital device, as specified in Part 15 of the FCC Rules. These specifications are designed to provide reasonable protection against such interference in a commercial installation. However, there is no guarantee that interference will not occur in a particular installation.

Chapter 2 - System Configuration

Repeater With Fixed Frequency Transceiver

In this configuration the CAT-200B supports a repeater with a CTCSS decoder and a transceiver on a fixed frequency.

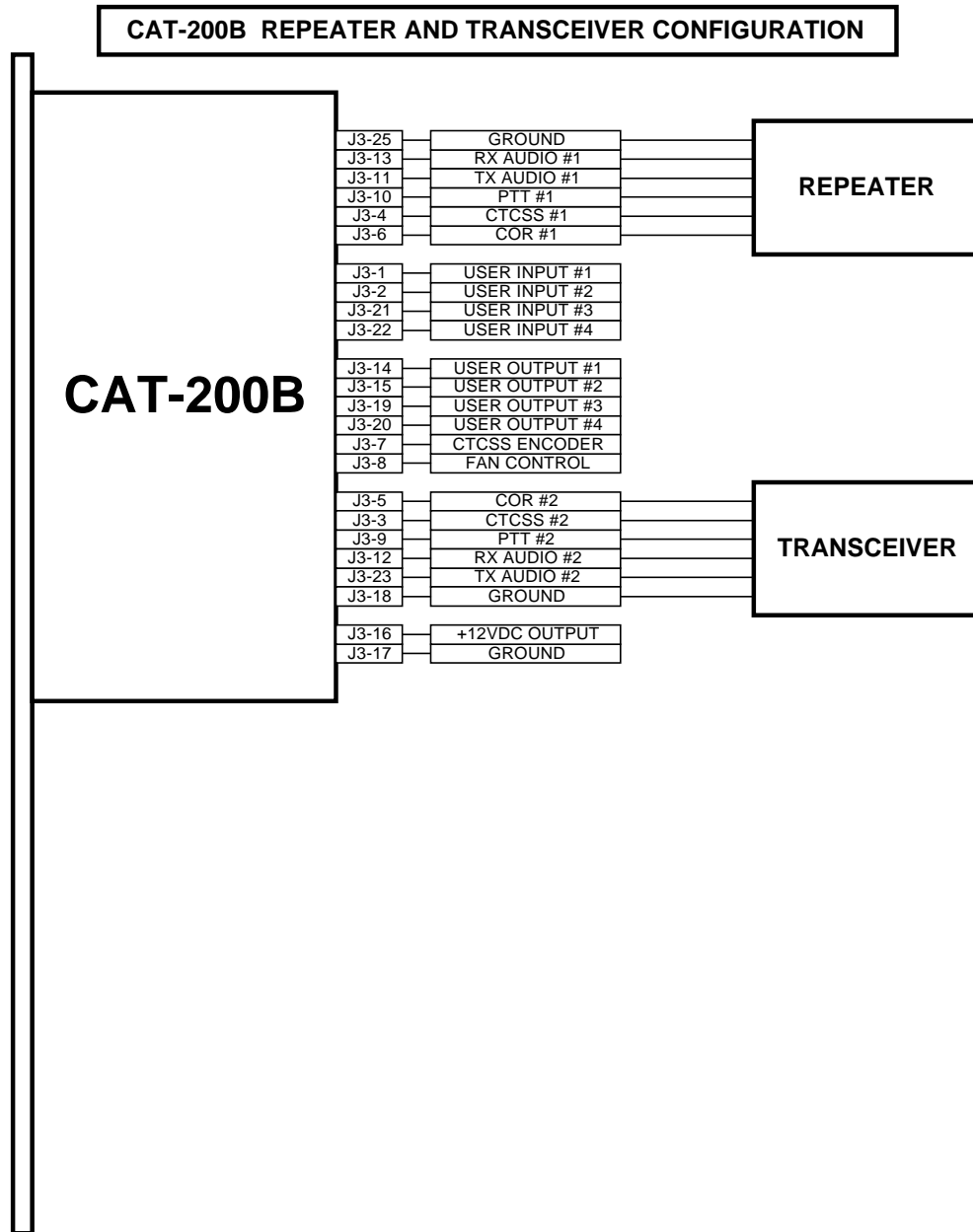

Figure 2-1

Dip Switch

An eight-position dipswitch configures various functions of the CAT-200B.

NOTE: Anytime a dipswitch is changed, DC power must be cycled for the CAT-200B controller to read the new setting.

Switch 1 This switch determines Repeater COR input logic. Switch #1 should be ON if the repeater receiver's COR is an active low and OFF if COR is active high.

Switch 2 This switch determines Repeater CTCSS input logic. Switch #2 should be ON if the repeater receiver's CTCSS is an active low and OFF if CTCSS is active high.

Switch 3 This switch determines Link COR input logic. This switch should be ON if the link receiver's COR is an active low and OFF if COR is active high.

Switch 4 This switch determines Link CTCSS input logic. Switch #4 should be ON if the link receiver's CTCSS is an active low and OFF if CTCSS is active high.

Switch 5 This switch determines if the CAT-200B is in the Repeater or Remote Transceiver Weather Station mode. This switch should be OFF if the CAT-200B is configured as a repeater controller. If the CAT-200B is configured as a remote weather station controller this switch should be ON. Consult Chapter 12 for a description of the changes in operation.

Switch 6 This switch is used to identify that the CI-200 Interface module is connected to the CAT-200B.

Switch 7 This switch is used to initialize the CAT-200B. Set this switch to ON. Cycle the power OFF and back ON. During power-up, the memory will be flushed and reloaded with default values. The voice will say: "RESET SYSTEM OK." Set dipswitch #7 to the OFF position.

Switch 8 This switch is used to program a new un-lock number. Set switch #8 to ON. The voice will say: "ENTER CONTROL." After the seven-digit unlock number is entered, set switch #8 to OFF. This switch is also used to activate the RS-232 port when the CI-200 is connected. Turn the power off set dipswitch #8 to on and apply power to the CAT-200B.

Chapter 3 - Repeater Control

The CAT-200B has 4 Zones for a total of 32 remote control channels. These channels can be manually controlled by DTMF commands on the repeater input.

Interrogation of Repeater Control Status by Radio

Key-up and send the control operator code [100] followed by the zone number and a zero. Un-key and the voice will read back the channels that are turned on in that zone. Example: Read Zone 2 channel status. If all the channels are turned off, the voice will say: "CLEAR."

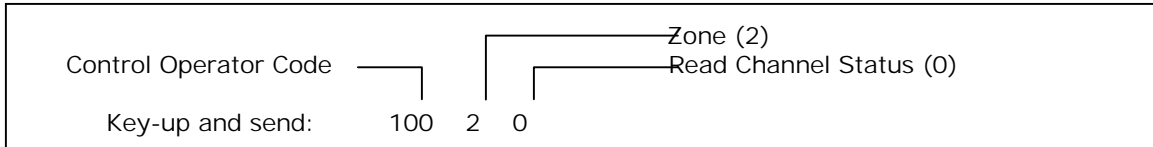

Un-key and the voice will say: "ONE FOUR EIGHT"

Changing Repeater Control Status by Radio

To change the status of a channel, key-up and send the control operator code [100] followed by the zone number, channel number and a [1] to turn the channel ON or a [0] to turn the channel OFF. Un-key and the voice will read back the zone, channel number and control activity. The voice will say: "ONE ONE ON." or "THREE FIVE OFF." Example: With a control operator prefix of 100, turn Zone 2 Channel 1 ON.

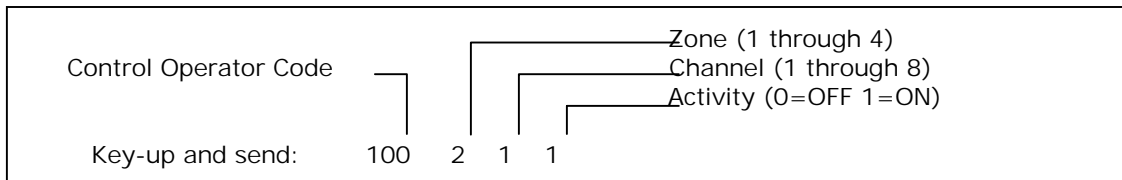

Un-key and the voice will say: "TWO ONE ON."

Repeater Control Channels

Zone 1

1	Repeater Transmit	Enable*
2	Repeater CTCSS	Enable
3	CTCSS and OR	Enable
4	Identification	Enable*
5	Courtesy Tone	Enable*
6	Hang Time	Enable*
7	DTMF Muting	Enable
8	Repeater Time-out	Enable*

Zone 2

1	Link Transmit	Enable*
2	Link CTCSS	Enable
3	Link Receive Only	Enable
4	Link Control	Enable*
5	Link Voice	Enable
6	Link Auto Disconnect	Enable
7	Link To Repeater Output	Enable
8	Link Time-out	Enable*

Zone 3

1	Logic Input #1	Enable*
2	Logic Input #1	Enable*
3	Logic Input #1	Enable*
4	Logic Input #1	Enable*
5	Switch #1	Enable
6	Switch #2	Enable
7	Switch #3	Enable
8	Switch #4	Enable

Zone 4

1	DTMF Pad Test	Enable*
2	Beacon Mode	Enable
3	Weather Report	Enable*
4	Fan Control	Enable
5	Voice ID	Enable*
6	Voice ID Link Inhibit	Enable
7	Forced [D] Key Entry	Enable*
8	CTCSS Encoder Control	Enable

* During initialization these control channels are set to the enable position.

Zone 1 - Repeater Control

1. Repeater Transmitter Enable

This is the master repeater switch. This channel must be enabled for normal repeater operation. The CAT-200B will continue to respond to control operator commands even when the repeater's transmitter is disabled. This channel will automatically be enabled after a dipswitch #7 initialization reset.

2. Repeater CTCSS Enable

When this channel is enabled, in addition to a COR input, an input from a CTCSS decoder at J3-4 must also be present before the repeater will activate. A COR input by itself will have no affect. To prevent loss of control, ~~DO NOT ENABLE THIS CHANNEL~~ unless a CTCSS decoder is connected to J3-4.

3. Repeater CTCSS OR Logic Enable

When this channel is enabled, the COR and CTCSS inputs will function as a (OR) logic input. This means activity on either the COR or CTCSS inputs will cause the controller to key the repeater's transmitter. This is a layered command. Therefore, Repeater CTCSS Enable, Zone 1 Channel 2 must be ON or this control function will have no effect.

4. Repeater ID Enable

When this channel is enabled, repeater voice ID will repeat subject to the setting of the ID timer. This ID will consist of up to 15 words selected from the voice vocabulary table and is programmed with the [*3101] command.

5. Courtesy Tone Enable

When this channel is enabled, a courtesy tone will occur when the COR signal is lost. To eliminate the courtesy tone, turn this channel OFF. The timeout timer will continue to be reset.

6. Transmitter Hang Time Enable

When this channel is enabled, the repeater's transmitter will remain on for a period of time determined by the COR to Beep and Beep to transmitter drop timers. To make the transmitter turn off the instant COR is lost, turn this channel OFF. This feature is useful when linking to other repeaters or during band openings.

7. DTMF Muting Enable

When this channel is enabled, anytime a DTMF tone is received, the audio will be turned off to the repeater's transmitter. The transmit audio will remain muted until a pre-determined time after the last DTMF tone is received. During the mute period, cover beeps are transmitted each second to indicate repeater activity. This feature prevents control commands from being repeated. It provides an extra measure of security. There may be times when it is desirable to pass the DTMF tones through the repeater. To temporarily disable DTMF muting, precede the DTMF string with a (#).

8. Repeater Time-Out Enable

Repeater time-out is user programmable with the [*601*] timer programming commands. When the CAT-200B is initialized, this timer defaults to 3 minutes. When this channel is turned off, the repeater will not time-out.

Zone 2 – Link Control

1. Link Transmitter Enable

This channel must be enabled for link operation. The CAT-200B will respond to the link 5001 on and 5000 off commands. This channel will automatically be enabled after a dipswitch #7 initialization reset.

2. Link CTCSS Enable

When this channel is enabled, in addition to a COR input, an input from a CTCSS decoder at J3-3 must also be present before the repeater will activate. A COR input by itself will have no affect.

3. Link Receive Only Enable

This channel must be enabled for link receive only operation. The CAT-200B will respond to the link receive only 5002 on and 5000 off commands. Any signals received by the link will be heard on the repeater's transmitter. However, conversations on the repeater will not be rebroadcast on the link transmitter.

4. Link Control Enable

The CAT-200B will only respond to the Link control commands [5000] and [5001] through the link input. This greatly reduces the possibility of the CAT-200B responding to a command meant for another repeater in the linking system. When this channel is enabled, link control commands will be accepted through the link receiver input.

5. Link Voice Enable

When this channel is enabled and the link is enabled, voice messages will be transmitted by the transceiver. When this channel is off, PTT #2 will not activate unless repeater COR #1 is active.

6. Link Auto Disconnect Enable

When this channel is enabled, the link will disconnect automatically after a period of repeater inactivity. The voice will say: "LINK TIME OUT". A repeater or transceiver COR will keep the link activate until the repeater returns to rest. A rest period of up to 29 minutes can be selected with the [*604*] programming command. When the CAT-200B is initialized, this timer defaults to 10 minutes.

7. Link To Repeater Output

This channel should be enabled when the transceiver on port 2 is linked to the output of a repeater. The repeater port time-out-timer is reset the instant repeater COR drops. The link port time-out-timer is disabled and the CAT-200B will identify in CW only.

8. Link Time-out Enable

Link time-out is user programmable with the [*602*] timer programming commands. When the CAT-200B is initialized, this timer defaults to 3 minutes. When this channel is turned off, the repeater will not time-out.

Zone 3 – Logic Inputs – Switch Outputs

1. Logic Input #1 Enable

When this channel is enabled, a logic active high input on connector J3-1 will activate voice message #3. This message is user programmable. The default message is "EMERGENCY POWER".

2. Logic Input #2 Enable

When this channel is enabled, a logic high input on connector J3-2 will activate voice message #4. This message is user programmable. The default message is "WEATHER ALERT".

3. Logic Input #3 Enable

When this channel is enabled, a logic high input on connector J3-21 will activate voice message #5. This message is user programmable. The default message is "INTRUDER ALERT".

4. Logic Input #4 Enable

When this channel is enabled, a logic high input on connector J3-22 will activate voice message #6. This message is user programmable. The default message is "HIGH TEMPERATURE".

5. Switch #1 Enable

When this channel is enabled, switch #1 is turned on. Connector J3 pin 14 will sink 50 MA to ground.

6. Switch #2 Enable

When this channel is enabled, switch #2 is turned on. Connector J3 pin 15 will sink 50 MA to ground.

7. Switch #3 Enable

When this channel is enabled, switch #3 is turned on. Connector J3 pin 19 will sink 50 MA to ground.

8. Switch #4 Enable

When this channel is enabled, switch #4 is turned on. Connector J3 pin 20 will sink 50 MA to ground.

Zone 4 - Miscellaneous Control

1. DTMF Pad Test Enable

When this channel is enabled, a repeater user is able to perform a test of their radio's 12 or 16-button keypad. As the numbers are being decoded, they are stored in memory. When the repeater user stops transmitting the controller will read back all the numbers that were decoded.

2. Beacon Mode

When this channel is enabled and there is no activity on the repeater, the CAT-200B will announce voice message 7 at an interval rate determined by the Beacon Timer [*605*]. Message 7 defaults to: "CAT-200B BEACON." The Beacon Timer defaults to one minute.

3. Weather Report Enable

When this channel is enabled, a repeater user is able to request a weather report.

4. Fan Control Enable

When this channel is enabled, and PTT #1 turns ON, the Fan Control output J3-8 will turn ON. After PTT #1 turns OFF this fan control output will remain ON for an additional 60 seconds. Use this output to control a fan relay to cool the repeater's transmitter. When this channel is enabled, User function switch #6 on, off, and momentary operation is not available.

5. Voice Identification Enable

When this channel is enabled, the CAT-200B will identify in voice, using message #1. When this channel is disabled, the CAT-200B will identify in CW only.

6. Voice Identification Link Inhibit Enable

When this channel is enabled, the CAT-200B will not accept an input from the link port while the voice identification is being sent on the repeater port.

7. Forced DTMF Entry D Key

When this channel is enabled it is possible to force a DTMF command even while port #1 is active. To force a DTMF command, end the command with a [D].

8. CTCSS Encoder Switch Enable

When this channel is enabled, user output switch #5 is converted into a CTCSS Encoder Switch output. When Port #1 goes active, user output #5 J2 pin 7 will turn ON. After Port #1 goes inactive, user output #5 will turn OFF. Use this output to control an external CTCSS encoder. When this channel is enabled, User function switch #5 on, off, and momentary operation is not available.

Chapter 4 - Repeater Operation

DTMF Keypad Test

Key-up, and enter [375], the DTMF keypad access code followed by the keypad numbers and letters to be tested. The entries can be in any order. Un-key, and the voice will read-back all numbers and letters that were decoded including the "STAR" and "POUND".

Link Disconnect

Key-up on the repeater's input and enter the link disconnect control number [5000]. The CAT-200B will disconnect the link and the voice will say: "LINK OFF."

Link Connect

Key-up on the repeater's input and enter the link connect control number [5001]. The CAT-200B will connect the repeater and link and the voice will say: "LINK ON."

Link Receive Only

Key-up on the repeater's input and enter the link receive only control number [5002]. The CAT-200B will connect the repeater and link and the voice will say: "LINK RECEIVER ON."

Forced DTMF Command Entry

During normal operation a DTMF command is entered when the port goes inactive. It is possible to force a DTMF command entry even while the port is active. The CAT-200 will accept the [D] key as an entry command.

DTMF Muting Override

With DTMF muting enabled, there may be times when it is desirable to pass the DTMF tones through the repeater or link transmitter. To temporarily disable DTMF muting, precede the DTMF string with a pound (#).

Voice Message Demo

Key-up and enter the voice prefix followed by a message number. The CAT-200B will key the transmitter and say the message stored at that location. Example: With a voice prefix number of 700, play message 3.

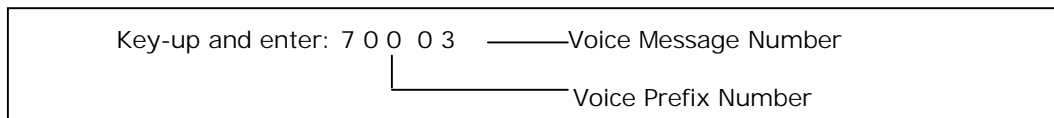

Weather Report

Key-up and enter the weather report prefix followed by a weather condition number. The CAT-200B will key the transmitter and provide a weather report. Example: With weather prefix number of 200, request the wind speed and direction.

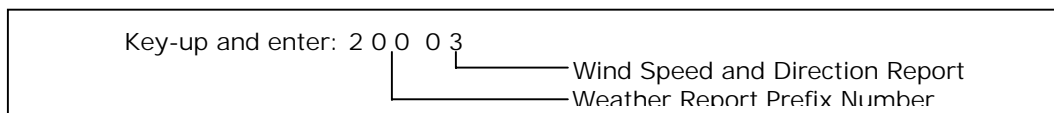

WEATHER REPORT COMMANDS			
00	Complete Weather Report	03	Wind Speed and Direction Report
01	Inside Temperature Report	04	Rain Fall Report
02	Outside Temperature Report	05	One Minute Wind Speed Report

Chapter 5 - Repeater Programming By DTMF Tone

This section describes how the repeater owner using a DTMF keypad programs the CAT-200B controller. The various types of program commands are described in detail and examples are given in the following text.

Initialization

To initialize the CAT-200B, set dipswitch #7 to on and cycle DC power. During power-up, the voice will say: "RESET SYSTEM OK." Set dipswitch #7 to off. Initialization consists of the following operations:

Dipswitch #7 Initialization

1. All memory locations are cleared.
2. The control channels marked with an [*] are enabled.
3. The unlock number is loaded with the default value [1234567].
4. The control operator prefix code is loaded with [100].
5. The timers are set to default values.
6. The voice ID is loaded with CAT-200B Repeater.

The control channels marked with an [*] are enabled.

Programming the Unlock Control Number

To program the UNLOCK code, set dipswitch #8 to the on position. The voice will say: "ENTER CONTROL." Key-up and enter a seven-digit number. Un-key, if the number is accepted, the voice will say: "CONTROL OK." If the number is rejected, the voice will say: "ENTER CONTROL." Key-up and enter the seven-digit number. Set dipswitch #8 to the off position.

Unlocking the Controller By Radio [1234567]

To unlock the controller, key-up and enter the seven digit unlock number. The voice will say: "CAT 200 CONTROL."

Locking the Controller By Radio [*0]

Key-up and send [*0]. Un-key, the controller will lockup and the voice will say: "CONTROL EXIT." The controller will lock-up automatically when the programming timer expires. The voice will say: "TIMER EXIT." The programming time limit is set for ten minutes.

NOTE: The CAT-200B must be ~~unlocked~~ to perform the following programming functions.

Send Synthesized Voice Message [*3001]-[*3012]

Key-up and send [*3001]. Un-key and the voice synthesizer will say the ID.

Program Synthesized Voice Message [*3101]-[*3112]

Key-up and send [*3101] followed by the three digit numbers that represents the words required to construct the ID. Memory space is provided for 15 entries. Refer to the Voice Vocabulary Word List. Example: Load Repeater ID with "W4XYZ Repeater"



VOICE MESSAGE NUMBER TABLE			
01	Repeater ID Message	07	Beacon Message
02	Weather Report Message	08	Link Connect Message
03	Voice Message #3	09	Link Disconnect Message
04	Voice Message #4	10	Link Auto Disconnect Message
05	Voice Message #5	11	Voice Message #11
06	Voice Message #6	12	Voice Message #12

Erase Synthesized Voice Message [*3201]-[*3212]

Key-up and send [*32XX]. Un-key and the voice will say: "CONTROL OK." The voice message will be erased.

CW ID Memory Storage

Memory space is provided for a CW identification. The buffer will accept 16 characters. If a repeater user talks over the voice ID, the CAT-200B will switch to the CW ID. If Zone 4 Channel 5 is disabled, the controller will ID in CW only. During initialization, the CW buffer is loaded with "CAT200/R."

Send Repeater CW ID [*33]

Key-up and send [*33]. Un-key and the CAT-200B will send the CW ID.

Program Repeater CW ID [*34]

Key-up and send [*34], followed by the two digit numbers that represents the call letter identification. Memory space is provided for (16) entries. Refer to the CW ID programming table. Example: Load CW ID memory buffer with DE W4XYZ/R.

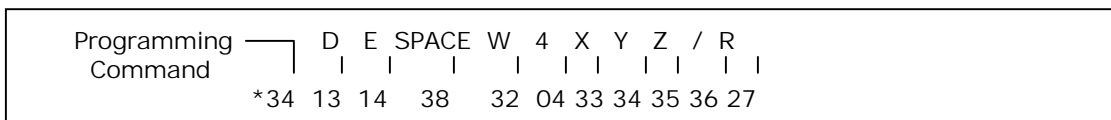

CW ID PROGRAMMING TABLE							
00=ZERO	05=FIVE	10=A	15=F	20=K	25=P	30=U	35=Z
01=ONE	06=SIX	11=B	16=G	21=L	26=Q	31=V	36=/
02=TWO	07=SEVEN	12=C	17=H	22=M	27=R	32=W	
03=THREE	08=EIGHT	13=D	18=I	23=N	28=S	33=X	
04=FOUR	09=NINE	14=E	19=J	24=O	29=T	34=Y	

Erase Repeater CW ID [*35]

Key-up and send [*35]. Un-key and the voice will say: "CONTROL OK." If the CW ID buffer is empty and a repeater user keys-up during a voice ID, the voice ID will stop.

Control Code And Prefix Number Memory

This memory area is reserved for storage of control and prefix numbers. These numbers can be from one to seven digits and will change to a default value when the CAT-200B is powered up with dip-switch #7 set to the on position.

Control Operator Prefix Number Repeater [*501*]

This programming command selects the control operator prefix number for the repeater port. This number must precede the command to change the zone control channels. Example: To program a Control Operator Prefix of [100], key-up and send:

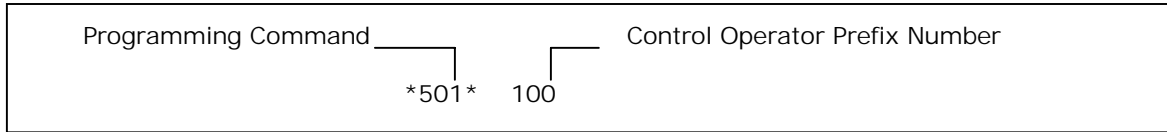

Un-key, the voice will say: "CONTROL OK." The default number is [100].

Voice Demonstration Control Number [*502*]

This number must be entered to PLAY one of the voice messages. This number must precede the voice message number. Example: To program a Voice Demonstration Control Number of 700, key-up and send [*502*700]. Un-key and the voice will say: "CONTROL OK."

DTMF Pad Test Number [*503*]

This number must be entered to initiate a DTMF keypad test. Example: To program a DTMF Pad Test Number of 375, key-up and send [*503*375]. Un-key and the voice will say: "CONTROL OK."

Weather Report Control Number [*504*]

This number must be entered to initiate a weather report. Example: To program a weather report Control Number of 200, key-up and send [*504*200]. Un-key and the voice will say: "CONTROL OK."

Link Disconnect Control Number [*505*]

This number is used to disconnect the link. Example: To program a link disconnect control number of 5000, key-up and send [*505*5000]. Un-key and the voice will say: "CONTROL OK."

Link Connect Control Number [*506*]

This number is used to connect the link. Example: To program a link connect control number of 5001, key-up and send [*506*5001]. Un-key and the voice will say: "CONTROL OK."

Link Receive Only Control Number [*507*]

This number is used to activate the link receive only mode. Example: To program a link receive only control number of 5002, key-up and send [*507*5002]. Un-key and the voice will say: "CONTROL OK."

Control Operator Prefix Number Link [*508*]

This programming command selects the control operator prefix number for the link port. This number must precede the command to change the zone control channels. To program a Control Operator Prefix of [300], key-up and send [*508*300]. Un-key, the voice will say: "CONTROL OK." The default number is [300].

Read Control And Prefix Numbers [*501 - *508]

Use this programming command to read the control operator and prefix numbers. Example: Key-up and enter [*501], un-key and the voice will say: "CODE FIVE ZERO ONE IS ONE ZERO ZERO."

Timer Memory

This memory area is reserved for storage of [8] timers. These timers are user programmable. When the CAT-200B is initialized, these timers are automatically loaded with default values.

Repeater Time-out [*601*]

This timer limits the length of a transmission. This timer is programmable between 60 and 1799 seconds. Example: To program the timer for 3 minutes, key-up and enter [*601*180]. Un-key and the voice will say: "CONTROL OK." When initialize, this timer defaults to 180 seconds.

Link Time-out [*602*]

The link time-out timer limits the maximum length of a transmission. This timer is programmable between 60 and 1799 seconds. Example: To program the timer for 3 minutes, key-up and enter [*602*180]. Un-key and the voice will say: "CONTROL OK." When initialize, this timer defaults to 180 seconds.

Repeater ID Timer [*603*]

This timer sets the time between transmissions of the repeater ID. The ID occurs when a repeater user stops transmitting. This timer is programmable between 60 and 1799 seconds. The timer default is 480 seconds.

Link Auto Disconnect Timer [*604*]

During link operation if Zone 2 channel 6 is enabled the link will disconnect automatically after a period inactivity. This timer is programmable between 60 and 1799 seconds. The timer default is 600 seconds.

Beacon Mode Timer [*605*]

When Zone 4 channel 2 is enabled and the repeater is inactive, the CAT-200B will automatically transmit voice message 7. The message will repeat per the setting of this timer. This timer is programmable between 60 and 1799 seconds. The timer default is 60 seconds.

Logic Input Message Timer [*606*]

This timer sets the time between logic input message announcements. The messages will continue to repeat as long as the respective logic input remains active high. This timer is programmable between 60 and 1799 seconds. The timer default is 600 seconds.

COR Drop to Courtesy Beep Timer [*610*]

This timer determines the time between loss of COR and the generation of the courtesy beep. This timer is programmable between 0.1 and 9.9 seconds. The timer default is 1 second.

Courtesy Beep to PTT Drop Timer [*611*]

This timer determines the time between the generation of the courtesy beep and the time the repeater transmitter turns off. This timer is programmable between 0.1 and 9.9 seconds. The timer default is 4 seconds.

Read Timer Settings [*601 - *611]

Key-up and send [*601]. Un-key and the voice synthesizer will read back the setting of the repeater's time-out timer. The voice will say: "TIMER 60 IS THREE MINUTES."

Audio Test Tone [*91 - *92 - *93]

The CAT-200B will generate a 1000Hz test tone. Use this tone as a reference when setting audio levels. To activate the tone, as TX1 audio, key-up and enter [*91]. To activate the tone, as TX2 audio, key-up and enter [*92]. To activate the tone, as TX1 and TX2 audio, key-up and enter [*93].

Program Repeater Courtesy Tone [*940 - *946]

The CAT-200B will generate this courtesy tone each time there is loss of signal by the repeater receiver and the link is turned OFF.

Program Repeater Courtesy Tone [*950 - *956]

The CAT-200B will generate this courtesy tone each time there is loss of signal by the repeater receiver and the link is turned ON.

Program Link Courtesy Tone [*960 - *966]

The CAT-200B will generate this courtesy tone each time there is loss of signal by the link receiver.

Program Link Courtesy Tone [*970 - *976]

The CAT-200B will generate this courtesy tone each time there is loss of signal by the link receiver and the link is in the receive only mode.

COURTESY TONE	FREQUENCY #1	FREQUENCY #2	COURTESY TONE	FREQUENCY #1	FREQUENCY #2
0	NONE	NONE	4	800Hz	800Hz
1	1000Hz	NONE	5	800Hz	1000Hz
2	800Hz	NONE	6	1000Hz	800Hz
3	1000Hz	1000Hz			

Exit Programming Mode [*0]

To exit the programming mode and return to normal repeater operation, key-up and send [*0]. Un-key and the voice will say: "CONTROLL EXIT." If you fail to exit the programming mode, the CAT-200B will return to normal repeater operation. The voice will say: "TIMER EXIT."

DTMF Programming Commands (Repeater)

ENTRY	DESCRIPTION	DEFAULT
*27	READ WEATHER STATION DATA SETTING	
*30XX	SEND VOICE MESSAGE (01-12)	
*31XX	PROGRAM VOICE MESSAGE (01-12)	
*32XX	ERASE VOICE MESSAGE (01-12)	
501	PROGRAM CONTROL OPERATOR NUMBER (REPEATER INPUT)	100
502	PROGRAM VOICE DEMONSTRATION PREFIX	700
503	PROGRAM DTMF PAD TEST NUMBER	375
504	PROGRAM WEATHER REPORT PREFIX	200
505	PROGRAM LINK DISCONNECT NUMBER	5000
506	PROGRAM LINK CONNECT NUMBER	5001
507	PROGRAM LINK RECEIVE ONLY NUMBER	5002
508	PROGRAM CONTROL OPERATOR NUMBER (LINK INPUT)	300
601	PROGRAM REPEATER TIME-OUT TIMER (60 - 1799 SECONDS)	300
602	PROGRAM LINK TIME-OUT TIMER (60 - 1799 SECONDS)	300
603	PROGRAM REPEATER ID TIMER (60 - 1799 SECONDS)	480
604	PROGRAM LINK AUTO DISCONNECT TIMER (60 - 1799 SECONDS)	600
605	PROGRAM BEACON MODE TIMER (60-1799 SECONDS)	60
606	PROGRAM LOGIC INPUT MESSAGE TIMER (60-1799 SECONDS)	600
610	PROGRAM COR DROP TO COURTESY BEEP TIMER (0.1 – 9.9 SECONDS)	1.0
611	PROGRAM COURTESY BEEP TO PTT DROP TIMER (0.1 – 9.9 SECONDS)	4.0
*91	TRANSMIT AUDIO TEST TONE (REPEATER)	
*92	TRANSMIT AUDIO TEST TONE (LINK)	
*93	TRANSMIT AUDIO TEST TONE (REPEATER + LINK)	
*9X	READ COURTESY TONE (4-5-6-7)	
*94X	PROGRAM REPEATER COURTESY TONE (0–6)	TONE 5
*95X	PROGRAM REPEATER COURTESY TONE WITH LINK ENABLED (0–6)	TONE 1
*96X	PROGRAM LINK COURTESY TONE (0–6)	TONE 2
*97X	PROGRAM LINK COURTESY TONE WITH LINK IN RECEIVE ONLY (0–6)	TONE 4
*0	MANUAL EXIT OF PROGRAMMING MODE	

Chapter 6 – Interfacing to Other Equipment

Interfacing the CAT-200B to your repeater system is a simple matter. A minimum of two inputs and two outputs are required for the CAT-200B to control a repeater. They are:

1. A COR signal to indicate when a signal is being received.
2. A receive audio signal containing DTMF tones to be processed for control.
3. A Push-To-Talk signal to tell the repeater transmitter to turn ON.
4. A transmit audio signal containing a combination of receive audio, synthesized voice, and courtesy tone.

Additional connections are required to realize all features of the CAT-200B.

Determining COR Logic

Locate your repeater receiver's COR output. This line has a DC voltage that changes state when a signal is being received. If the COR line is 0 volts and goes to a positive voltage when a signal is received it is said to be (positive logic) or active HIGH. If the COR line is a positive voltage, and goes to 0 volts when a signal is received it is said to be (negative logic) or active LOW. Note: 0 volts is any voltage less than 0.8VDC. A positive voltage is any voltage greater than 3.0VDC. Set dipswitch #1 on the CAT-200B to ON for (negative logic) and OFF for (positive logic).

Connection to Receiver

Connect the repeater receiver audio output to J3-13 and the COR to J3-6 of the CAT-200B. Verify this line changes from less than 0.8VDC to greater than 3.0 VDC. If the COR line will not meet these limits it may be necessary to add a pull-up resistor to the COR #1 line. This may also be true for the COR #2 input. Space is provided on the CAT-200B board to add pull-up resistors.

Connection to Transmitter

Locate your repeater's Push-To-Talk input. When grounded, this line will make the repeater transmit. Connect the CAT-200B PTT #1 output (J3-10) to this line. Locate your repeater's TX audio input. This is the line where the audio signal used to modulate the transmitter is applied. Connect the TX1 AUDIO (J3-11) to this line.

Connection to CTCSS Decoder

If your repeater receiver has a CTCSS decoder output, connect it to J3-4. In addition to COR, the CAT-200B requires an active high input to represent a CTCSS input. If the CTCSS input is active low set dipswitch #2 on.

Interface Review

1. Are dipswitches #1 through #8 in their proper positions?
2. Is the PTT-1 output at J3-10 connected to the transmitter PTT input?
3. Is the TX1 Audio at J3-11 connected to the transmitter audio input?
4. Is the COR-1 at J3-6 connected to the repeater receiver COR output?
5. Is dipswitch #1 ON for active low COR or OFF for active high COR?
6. Is the COR level changing from less than 0.8 VDC to greater than 3.0 VDC?
7. Is the RX1 AUDIO at J3-13 connected to the receiver audio output?
8. Is the audio input level sufficient for the DTMF decoder?

Connector Kit

Included with the controller is a connector kit containing a 25 pin "D" connector to mate with J3, a 2.5mm power plug to mate with J2 (center pin is [+]), two 2200 ohm resistors and two .0047uF capacitors. If the COR inputs are active low, install the 2200 ohm resistors as pull-ups on the board at the R36 and R37 positions. If the receiver's COR circuit is not capable of pulling down the 2200 ohm resistor increase the resistor value to 10K ohms. If the controller is supplied with discriminator audio install the .0047uF capacitors on the board at the C10 and C11 positions to de-emphasize the audio.

Power Supply

The CAT-200B is powered by an external 12VDC power supply. Connect the positive lead of the supply to the center pin of the coaxial power connector J2 and the negative lead to the outer conductor.

Audio Level Adjustment

The audio mixing-switching circuits of the CAT-200B are optimized around an input and output of – 10dBm (220mV).

Connect a signal generator to the repeater's receiver input. Adjust the signal generator's output for a standard test signal of 1000 Hz at 3 KHz deviation. If a signal generator is not available, select a hand-talkie that you suspect has the DTMF tone pad adjusted for approximately 3 KHz deviation.

Key-up on the repeater input and send a DTMF tone. Adjust the RX1 control R10 for 220 mVAC at TP1. If a link transceiver is connected to the CAT-200B, key-up and send the LINK enable command [5001]. Key-up on the LINK receiver input and send a DTMF tone. Adjust RX2 control R16 for 220 mVAC at TP1.

Once the RX1, and RX2 audios are adjusted, key-up on the repeater input and send a DTMF tone. Monitor the REPEATER transmitter. Adjust the TX1 Audio level control (R4) as required to set the repeater transmitter deviation to 3 KHz or as desired. If the repeaters transmit audio input is very sensitive and you find the TX1 Audio level control near minimum, it is strongly recommended that an external voltage divider be installed at the audio input of the repeater's transmitter.

If a link transceiver is connected, key-up on the repeater input and send a DTMF tone. Monitor the LINK transmitter. Adjust the TX2 Audio level control (R11) as required to set the link transmitter deviation to 3 KHz or as desired. If the link transmit audio input is very sensitive and you find the TX2 Audio level control is near minimum, set the jumper plug at J4 between pins 1 and 2.

Compare the receive and synthesized voice audio and adjust the voice Level (R28) as desired. The synthesized voice should be slightly lower than the receive audio.

Unlock the CAT-200B by keying-up on the repeater input and entering: [1234567]. Key-up and enter the [*91] test tone programming command. Verify that the test tone provides approximately 1.5 KHz transmitter deviation. Key-up and enter [*0] to exit the programming mode.

Test Point TP1 – Receiver Audio

This test point displays the receive audio level at the input of the DTMF decoder. Adjust RX1 and RX2 for 200mVAC of DTMF audio.

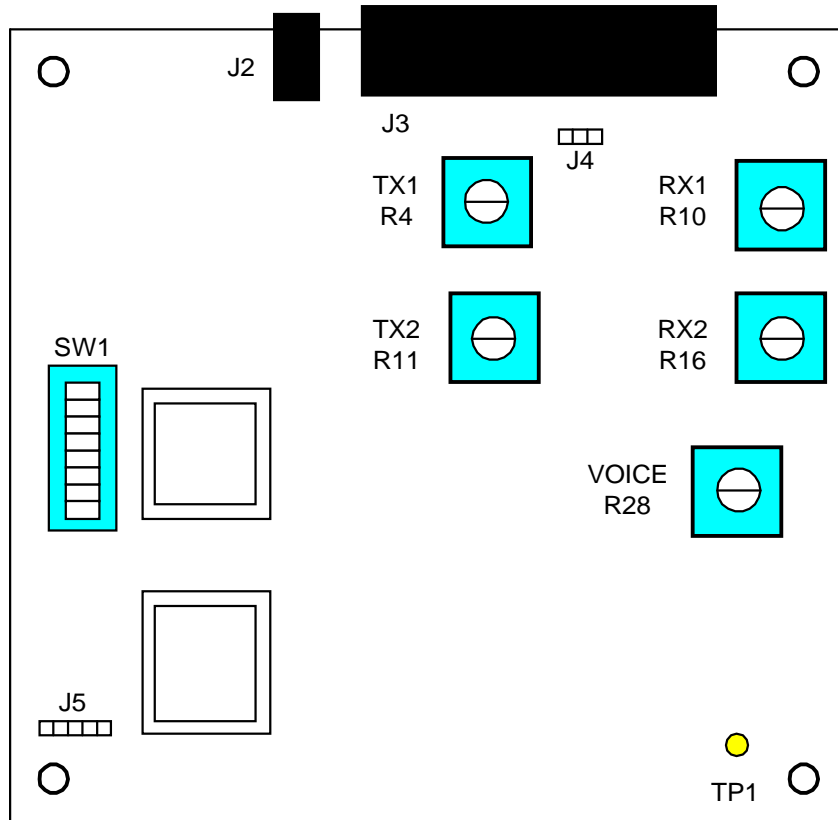
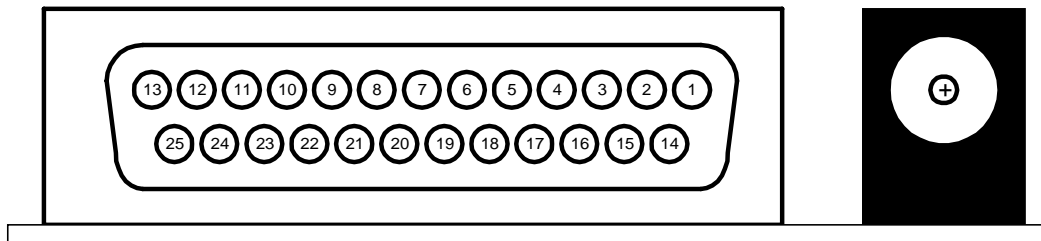

Figure 6-1

Repeater Interface (J3)

Connector J3 provides an interface to the repeater and transceiver.



Radio Interface

1. LOGIC INPUT #1	10. PTT #1	19. SWITCH #3
2. LOGIC INPUT #2	11. TX AUDIO #1	20. SWITCH #4
3. CTCSS #2	12. RX AUDIO #2	21. LOGIC INPUT #3
4. CTCSS #1	13. RX AUDIO #1	22. LOGIC INPUT #4
5. COR #2	14. SWITCH #1	23. TX AUDIO #2
6. COR #1	15. SWITCH #2	24. RESERVED
7. CTCSS ENCODER SWITCH	16. +12VDC OUTPUT	25. GROUND
8. FAN CONTROL	17. GROUND	
9. PTT #2	18. GROUND	

Figure 6-2

Weather Station Interface (J5)

Connector J5 provides an interface to the CI-200 Interface Board.

1. +12VDC	2. GROUND	3. +5VDC	4. RX DATA	5. TX DATA
-----------	-----------	----------	------------	------------

Figure 6-3

CTCSS Decoder

Connect the TS-64 CTCSS Encoder/Decoder assembly to the CAT-200B as described in Figure 6-5. The decoder must be connected to discriminator audio. Speaker or volume control audio will have insufficient low frequency CTCSS tone content.

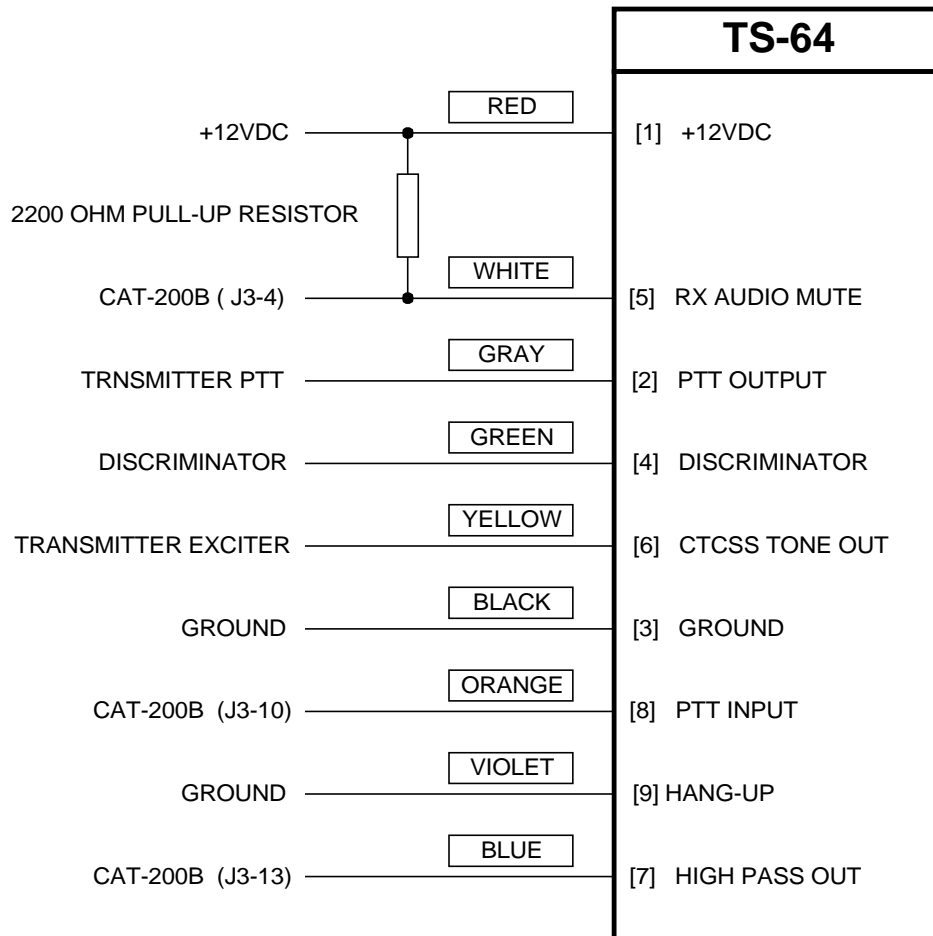

Figure 6-5

Connector Kit

The connector kit contains a DB25 male connector with hood, a 2.5 mm DC power plug, two 2200-ohm pull-up resistors and two .0047uF capacitors. If the CAT-200B is supplied with discriminator audio, install the .0047uF capacitor on the board at position C10 or C11 in the case of the link receiver. If required install the 2200 ohm resistors on the CAT-200B board to pull-up the COR inputs.

Chapter 7 - Weather Station Interface

Provide timely weather announcements on your repeater system. Connect a Peet Brothers Ultimeter ® U-100, U-800 or U-2000 Weather Station to the serial port of the CAT-200B through the CI-200. Integrate temperature, wind speed, direction, and rainfall rate into any of the CAT-200B voice messages. Program a special weather report message as part of your identification.

Peet Brothers Weather Station Setup

Connect the weather station component cables as described in the weather station owner's manual. Install the 9 volt battery. If will be necessary to set the weather station's clock.

Peet Brothers Interconnect

Purchase a four-conductor telephone cable. Hold the modular connector with the latch down and the gold contacts up. Check that the black wire is on the left side of the modular connector. Cut the modular connector off of the other end of the telephone cable. Strip the cable and cut off the red and yellow wires. Strip the green and black wires.

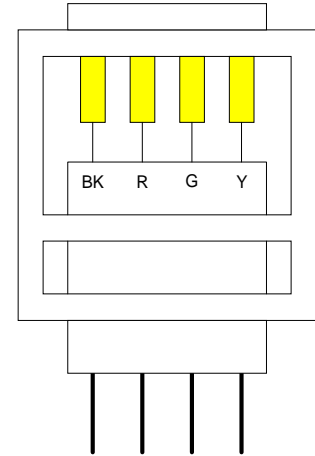

CAT-200B - Weather Station Interface

Connect your Peet Brothers Weather Station to the CI-200 as described in Figure 7-1. On the CI-200 set the J2 jumper plug to the WS position. On the CAT-200B set dipswitch #6 to ON. Set Zone 4 Channel 3 to on to enable weather station information.

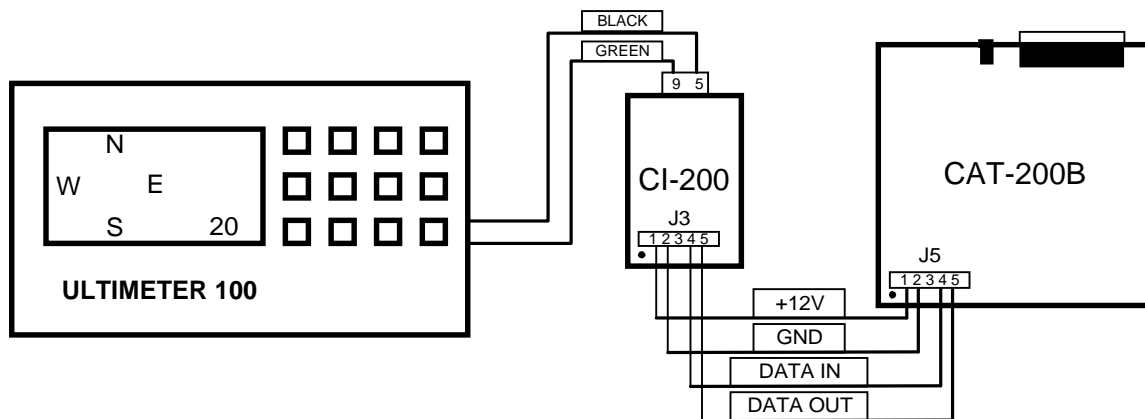

Figure 7-1

To provide continuous weather information to the CAT-200B, the weather station must be in the "LONG DATA MODE." On the keyboard display unit: press and hold the [CLEAR] and [RAIN FALL] keys for three seconds.

To test the interface, unlock the CAT-200B and enter the [*27] programming command. If the controller is receiving data, the voice synthesizer will say: "LONG DATA VERIFY." If a problem exists the voice will say "ERROR NO DATA."

Weather Report

Key-up and enter the weather report prefix followed by a weather condition number. The CAT-200B will key the transmitter and provide a weather report. Example: With weather prefix number of 200, request the wind speed and direction.

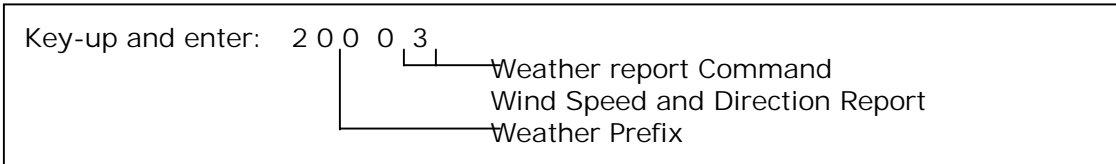

WEATHER REPORT COMMANDS	
00	Complete Weather Report
01	Inside Temperature Report
02	Outside Temperature Report
03	Wind Speed and Direction Report
04	Rain Fall Report
05	Five Minute Peak Wind Speed Report
06	High and Low Temperature
07	Wind Chill
08	Air Pressure (Not Available in U-100)
09	Humidity (Not Available in U-100)

CAT-200B Programming Information

Nine new voice variables have been added to the vocabulary list to announce weather information during the repeater ID or other voice messages.

VARIABLE	DESCRIPTION	EXAMPLE (VARIABLE IN BOLD)
110	INSIDE TEMPERATURE	75 Degrees
111	OUTSIDE TEMPERATURE	40 Degrees
112	WIND SPEED AND DIRECTION	The wind is out of the EAST at 10 miles per hour
113	RAIN FALL	Today's rain fall is .2 inches
114	ONE MINUTE WIND SPEED	The one minute wind speed is 25 miles per hour
115	HIGH / LOW TEMPERATURE	
116	WIND CHILL	
117	AIR PRESSURE	
118	HUMIDITY	

Program Voice Message With Temperature Variables

To program a voice message with the temperature load the number [111]. Example: Load message 3 with the actual temperature. The voice will say: "THE TEMPERATURE IS **75** DEGREES]"



Program Voice Message With Wind Speed And Direction Variables

To program a voice message with the wind speed and direction load the number [112]. Example: Load message 2 with the actual wind speed and direction. The Voice will Say: "THE WIND IS OUT OF THE EAST AT 10 MILES PER HOUR]." If the wind speed is 0 miles per hour, the voice will say: "THE WIND IS CALM".

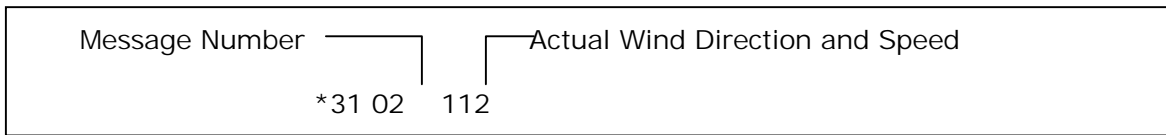

Program Voice Message With Rain Fall Variables

To program a voice message with the rainfall load the number [114]. Example: Load message 3 with the rainfall. The voice will say: "TODAY'S RAIN FALL IS .1 INCHES]"



The Peet Brothers weather station resets the rain gauge at 12:00 A.M. and is under the control of the Peet Brothers weather station clock.

Program Voice Message With Complete Weather Report

To program a voice message with a complete weather report load message 2 with: "THE TEMPERATURE IS 75 DEGREES THE WIND IS OUT OF THE EAST AT 10 MILES PER HOUR."

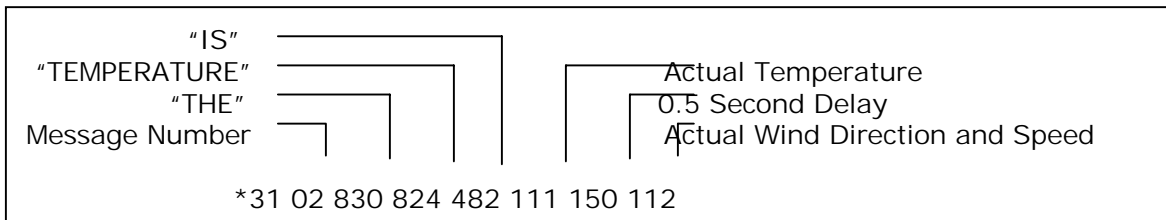

Chapter 8 - Voice Vocabulary

Zero	000	Call	272	Get	412	Miles	600
One	001	Calling	273	Go	413	Minus	603
Two	002	Calm	271	Golf	414	Minute	604
Three	003	Cancel	274	Good	415	Minutes	605
Four	004	Cat	275	H	440	Mobile	606
Five	005	Caution	276	Ham	443	Monday	608
Six	006	Change	279	Hamfest	444	Month	609
Seven	007	Charlie	280	Have	445	Move	611
Eight	008	Check	281	Hertz	449	N	620
Nine	009	Clear	283	High	450	Near	621
Ten	010	Closed	285	Hotel	453	Net	623
Eleven	011	Club	286	Hour	454	New	624
Twelve	012	Code	287	Hours	455	Next	625
Thirteen	013	Come	288	Hundred	456	Night	626
Fourteen	014	Complete	289	I	470	No	627
Fifteen	015	Condition	292	Ice	471	Normal	628
Sixteen	016	Connect	294	Icing	472	North	629
Seventeen	017	Contact	295	Identify	473	Not	630
Eighteen	018	Control	296	In	475	November	631
Nineteen	019	D	310	Inches	474	Now	632
Twenty	020	Danger	311	India	477	Number 633	
Thirty	030	Data	312	Information	478	O	650
Forty	040	Date	313	Ing (suffix).	479	Of	653
Fifty	050	Day	314	Inputs	480	Off	654
Sixty	060	Days	315	Intruder	481	On	656
Seventy	070	Decrease	317	Is	482	Open	657
Eighty	080	Degree	318	It	483	Operator	659
Ninety	090	Delay	319	J	500	Or	660
A	210	Delta	320	Juliet	502	Oscar	662
A.M.	211	Direction	322	K	530	Other	663
Above	214	Do	323	Key	531	Out	664
Adjust	217	Down	324	Keypad	532	Over	665
Advise	218	E	340	Kilo	533	P	680
Again	221	East	341	L	550	P.M.	681
Alert	223	Echo	342	Last	552	Papa	682
All	224	Ed (suffix)	343	Left	554	Per	683
Alpha	225	Emergency	344	Let	556	Recent	684
Amateur	228	End	345	Lima	559	Plan	688
An	230	Enter	346	Link	561	Please	689
And	231	Error	348	List	562	Plus	690
Area	235	Exit	350	Load	563	Point	691
As	236	F	370	Long	566	Pound	694
Assistance	237	Failure	372	Low	568	Power	695
At	239	Fall	393	Lower	569	Preset	697
Attempt	240	Fast	374	M	580	Press	698
Attention	241	Feet	376	Machine	581	Pressure	699
B	250	File	378	Make	583	Q	720
Back	251	For	004	Manual	585	Quebec	721
Band	252	Foxtrot	386	Many	586	R	730
Base	253	Freezing	387	Meeting 593		Radio	731
Beacon	254	Frequency	388	Mega	594	Rain	733
Below	255	Friday	389	Message	595	Range	735
Bravo	257	From	390	Meter	596	Ready	737
By	260	Full	392	Meters	597	Receive	738
C	270	G	410	Mike	599	Receiver	739

Remote	743	Tuesday	849	Peak Wind	114
Repeat	745	Turn	850	Hi/Low Temp	115*
Repeater	746	Type	851	Wind Chill	116*
Reset	747	U	870	Air Pressure	117*
Right	749	Uniform	871	Humidity	118*
Road	750	Unit	872		
Roger	751	Until	874	Link Port Control	
Romeo	752	Up	875	Link Port Off	120
S	770	Use(noun)	876	Link Port On	121
Saturday	772	Use(verb)	877	Link Port Rec	122
Seconds	774	V	880		
Send	777	Verify	882	User Switch	
Sent	778	Version	883	Control	
Service	781	Victor	884	500 mS Delay	150
Set	782	W	890	UF #1 OFF	151
Severe	783	Wait	891	UF #1 ON	152
Short	784	Warning	892	UF #1 MON	153
Sierra	788	Watch	893	UF #2 OFF	154
Slow	790	Watts	894	UF #2 ON	155
Snow	791	Weather	896	UF #2 MON	156
South	792	Wednesday	897	UF #3 OFF	157
Speed	793	Week	898	UF #3 ON	158
Star	795	Weekday	899	UF #3 MON	159
Start	796	Welcome	900	UF #4 OFF	160
Stop	797	West	902	UF #4 ON	161
Storm	798	What	903	UF #4 MON	162
Sunday	799	Whiskey	904	UF #5 OFF	163
System	801	Will	905	UF #5 ON	164
S (plural)	802	Wind	906	UF #5 MON	165
T	820	Wind Chill	907	UF #6 OFF	166
Tango	821	With	908	UF #6 ON	167
Temperature	824	X	920	UF #6 MON	168
Test	826	X-Ray	921		
Than	827	Y	930	* Requires CI-200	
Thank-You	828	Yankee	931		
That	829	Year	932	NOTE:	
The (short E)	830	Yes	934	Humidity requires	
The (long E)	831	You	936	Ultimeter 800 or	
Then	832	Your	937	2000.	
This	833	Z	950	Air Pressure requires	
This-is	834	Zed	951	Ultimeter 2000.	
Thunderstorms	836	Zero	952		
Thursday	837	Zone	953		
Time	838	Zulu	954		
Timer	839				
To	002	Pause			
Today	840	Pause 1	960		
Today's	852	Pause 2	961		
Tomorrow	841	Pause 3	962		
Tone	854	Pause 4	963		
Tonight	842				
Tornado	843	Weather Variables			
Traffic	845	Inside Temp	110		
Transceiver	853	Outside Temp	111		
Transmit	846	Wind Speed	112		
Try	848	Rainfall	113		

Chapter 9 - Diagram

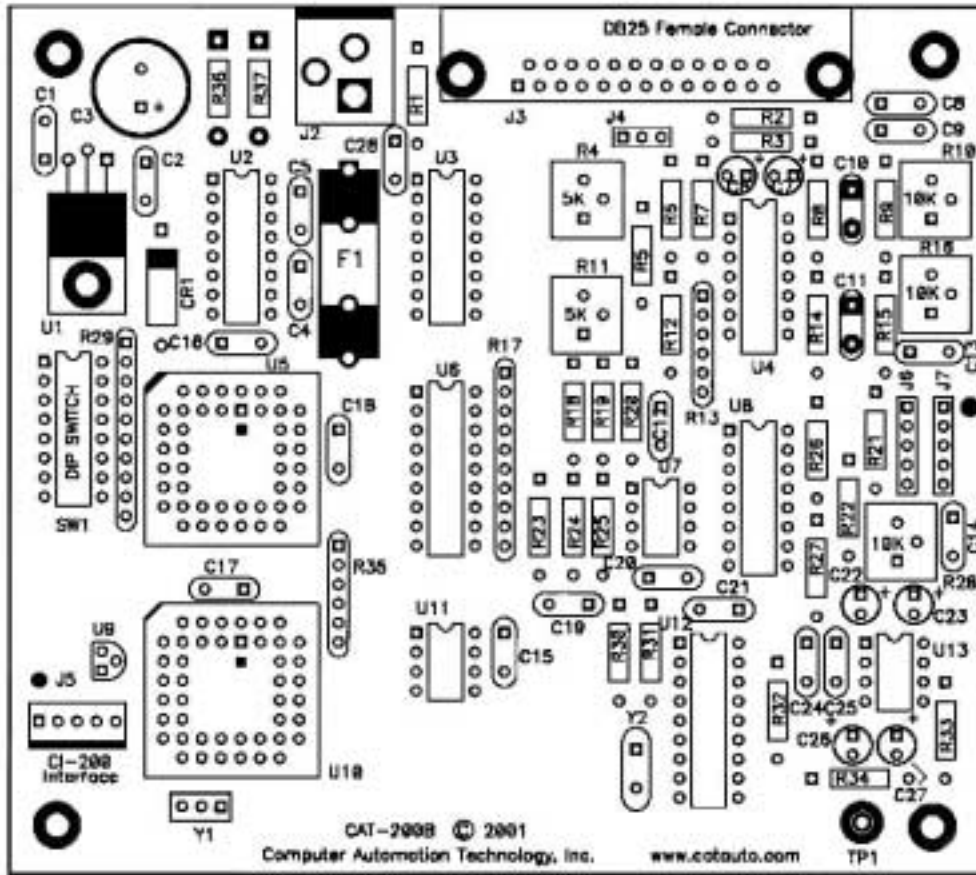

CAT-200B
Figure 9-1

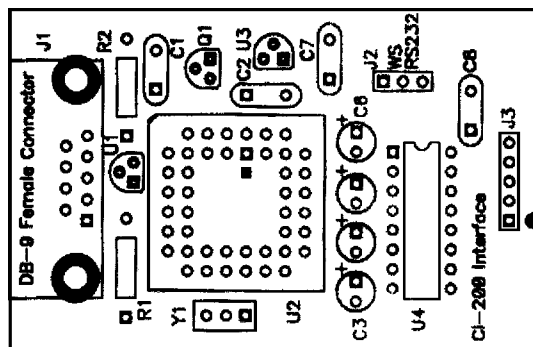

CI-200
Figure 9-2

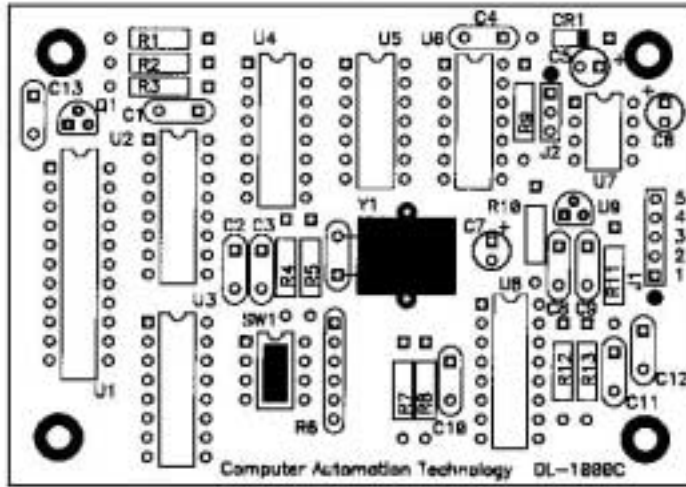

DL-1000C Audio Delay Board
Figure 9-3

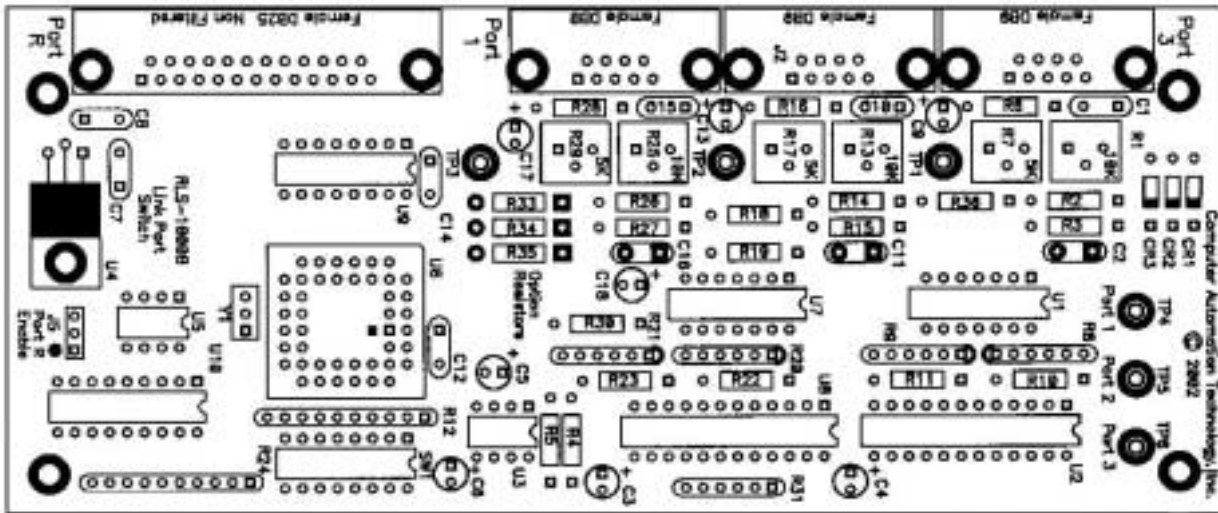

RLS-1000B Remote Link Switch
Figure 9-4

Chapter 10 - Schematic

Controller Board (CAT-200B)
Controller Board (CAT-200B)

Sheet 1 of 2
Sheet 2 of 2

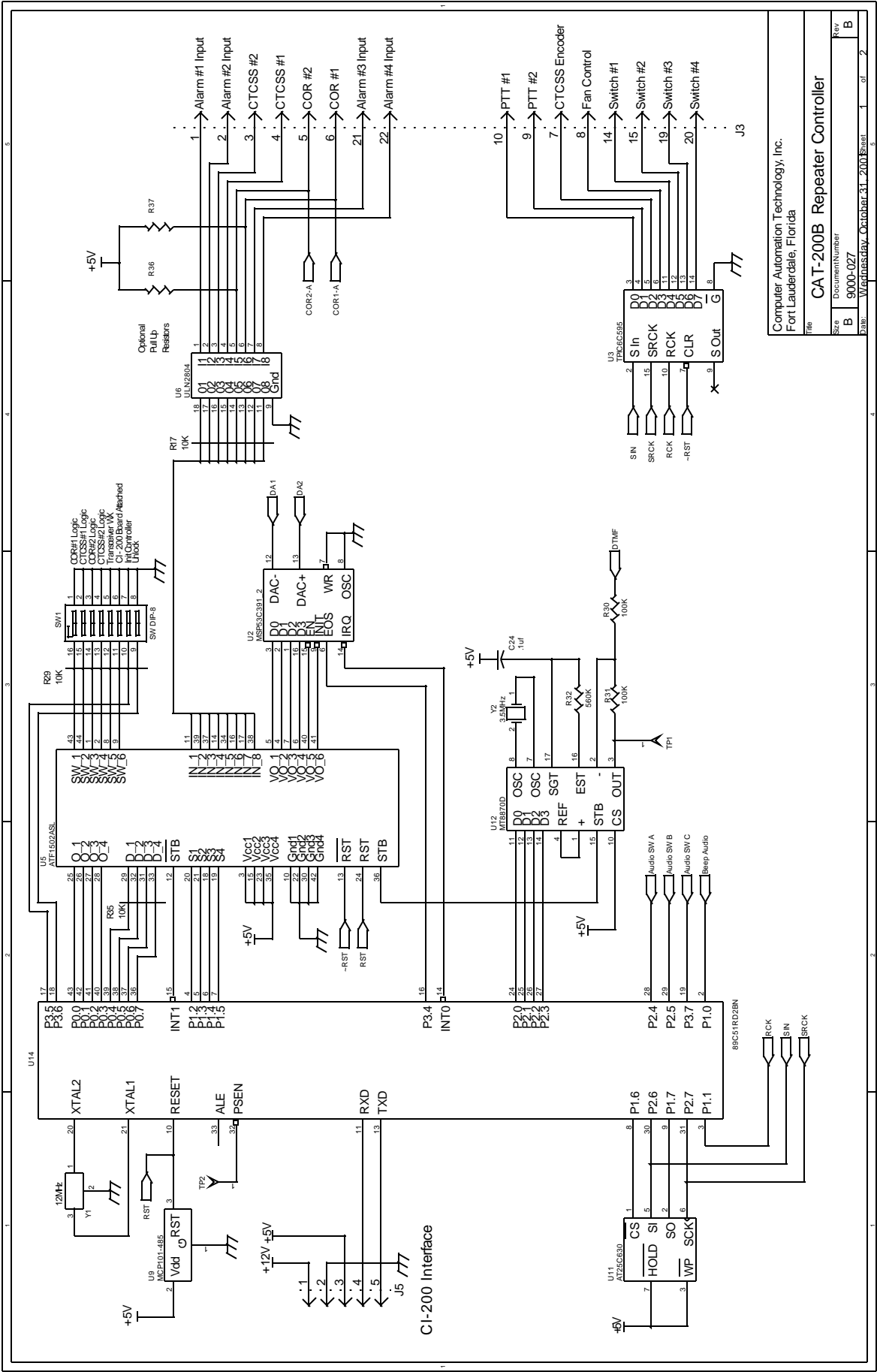

Computer Automation Technology, Inc.
Fort Lauderdale, Florida

Title CAT-200B Repeater Controller

Size	Document Number	Rev
B	9000-027	B
Date	Wednesday, October 31, 2001	Sheet 1 of 2

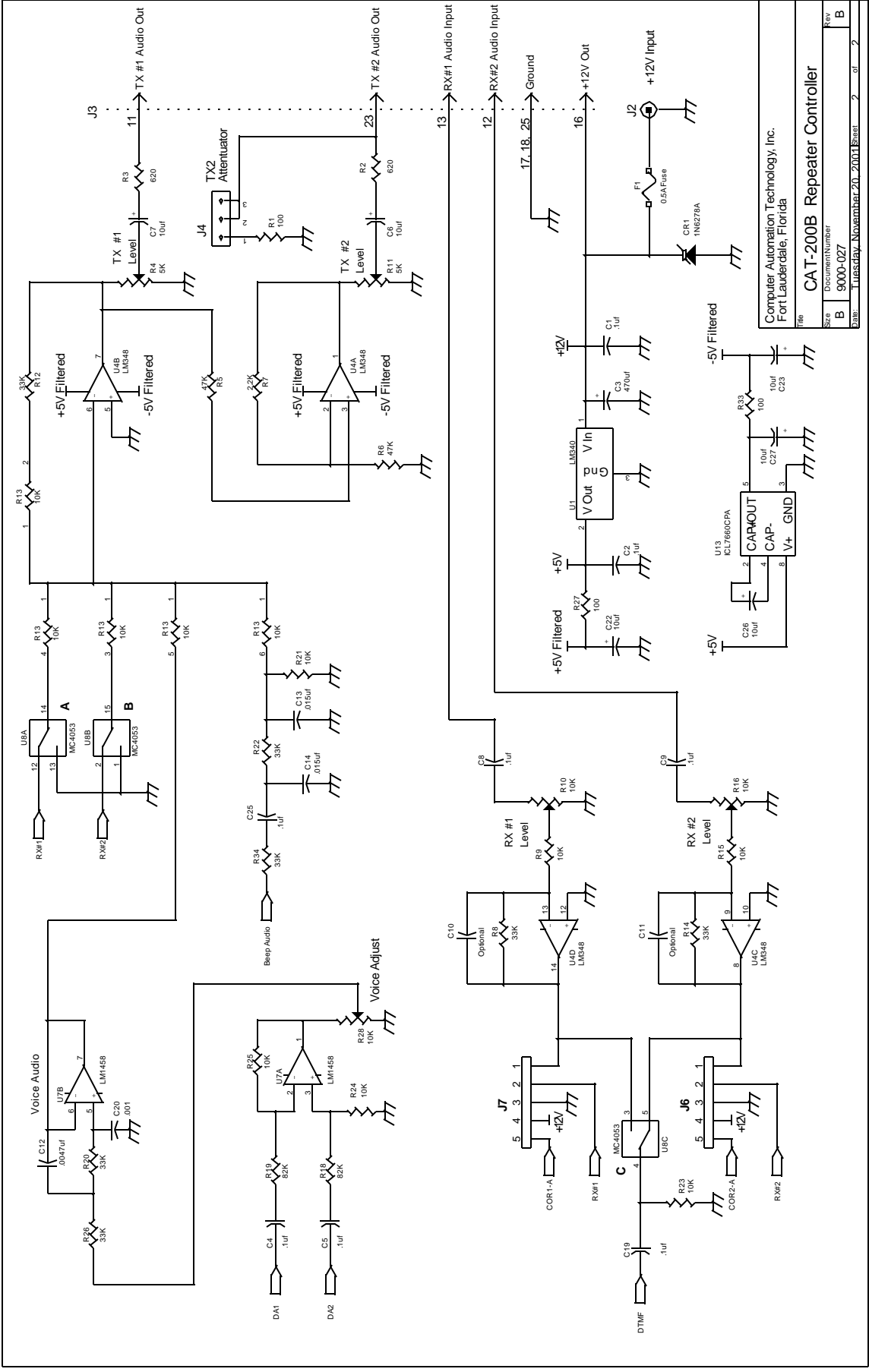

Computer Automation Technology, Inc.
 Fort Lauderdale, Florida

Title		CAT-200B Repeater Controller	
Size	Document Number		
B	9000-027		
Tab	Tuesday, November 20, 2001	Sheet	2 of 2
		Rev	B

Chapter 11 - Part List

CAT-200B Controller

1	Capacitor	.001UF 50V	C20
2	Capacitor	.015UF 50V	C13,C14
1	Capacitor	.0047UF 50V	C12
1	Capacitor	.1UF 50V	C1,C2,C4,C5,C8,C9,C15,C16,
5			C17,C18,C19,C21,C24,C25,C28
6	Capacitor	10uf 16V	C6,C7,C22,C23,C26,C27
1	Capacitor	470uf 50V	C3
2	Capacitor	Optional	C10,C11
1	Connector	Berg 1X3	J4
1	Connector	Berg 1X5	J5
1	Connector	DB25	J3
1	Connector	DC Power	J2
1	Crystal	3.58MHz	Y2
1	Diode	1N6278A	CR1
1	Fuse	0.5 AMP	F1
2	Header	1X5	J6,J7
1	I.C.	25C320/P	U11
1	I.C.	P89C51RD2HBA	U10
1	I.C.	MC101-485	U9
1	I.C.	ILC7660	U13
1	I.C.	LM340-05	U1
1	I.C.	LM348	U4
1	I.C.	LM1458	U7
1	I.C.	MC4053	U8
1	I.C.	MSP53C391	U2
1	I.C.	MT8870D	U12
1	I.C.	ATF1502ASL-25	U5
1	I.C.	TPIC6C595	U3
1	I.C.	ULN2804	U6
1	Resistor	2.2K Ohm .25W	R7
2	Resistor	5K Variable	R4,R11
1	Resistor	10K 6 Pin SIP	R13,R35
2	Resistor	10K 10 Pin SIP	R17,R29
7	Resistor	10K Ohm .25W	R6,R9,R15,R21,R23,R24,R25
3	Resistor	10K Variable	R10,R16,R28
7	Resistor	33K Ohm .25W	R8,R12,R14,R20,R22,R26,R34
5	Resistor	47K Ohm .25W	R5
2	Resistor	82K Ohm .25W	R18,R19
3	Resistor	100 Ohm .25W	R1,R27,R33
2	Resistor	100K Ohm .25W	R30,R31
1	Resistor	560K Ohm .25W	R32
2	Resistor	620 Ohm .25W	R2,R3
1	Resonator	12MHz	Y1
1	Switch	DIP 8 Position	SW1

CI-200 Interface Board

1	Capacitor	.001UF 50V	C1
3	Capacitor	.1UF 50V	C2,C7,C8
4	Capacitor	10uf 16V	C3,C4,C5,C6
1	Connector	Berg 1X3	J2
1	Connector	Berg 1X5	J3
1	Connector	DB9	J1
1	I.C.	LM78L05	U3
1	I.C.	MAX232	U4
1	I.C.	MP-102	U1
1	I.C.	89C52	U2
2	Resistor	4.7K Ohm .25W	R1,R2
1	Resonator	12 MHz	Y1
1	Transistor	2N7000	Q1

DL-1000C Audio Delay Board

7	Capacitor	0.1uF 50V	C1,C4,C8,C9,C10,C11,C12
3	Capacitor	10uF 16V	C5,C6,C7
2	Capacitor	18pF 50V	C2,C3
1	Capacitor	.001uF 50V	C13
1	Crystal	2.048Mhz	Y1
1	Diode	1N4148	CR1
1	Header	1X3	J2
1	Header	1X5	J1
1	I.C.	74HC73	U5
1	I.C.	74HC02	U6
2	I.C.	74HC4520	U2,U3
1	I.C.	CY7C187	U1
1	I.C.	MC7805AC	U9
1	I.C.	74HC4060	U4
1	I.C.	TP3054	U8
1	I.C.	7660CPA	U7
3	Resistor	10K 5% 1/4W	R1,R3,R11
1	Resistor	4.7K 5% 1/4W	R9
1	Resistor	22K 5% 1/4W	R13
1	Resistor	100 5% 1/4W	R10
2	Resistor	47K 5% 1/4W	R2,R12
3	Resistor	330 5% 1/4W	R4,R7,R8
1	Resistor	10MEG 5% 1/4W	R5
1	Resistor	10K 6pin Network	R6
1	Switch	Dip 4 Pole	SW1
1	Transistor	2N7000	Q1

RLS-1000B Remote Link Switch

8	Capacitor	10uF 16V	C3,C4,C5,C6,C9,C13,C17,C18
7	Capacitor	0.1uF 50V	C1,C7,C8,C10,C12,C14,C15
3	Capacitor	.0047uF 50V	C2,C11,C16 (Select Part)
3	Connector	DB-9F	J1,J2,J3
1	Connector	DB-25F	J4
1	Crystal	12MHz	Y1
3	Diode	1N4148	CR1,CR2,CR3
1	Header	1X3	J5
1	I.C.	LM340T-5	U4
1	I.C.	ICL7660	U3
1	I.C.	AT89C5124JC	U6
1	I.C.	TD62084AP	U10
1	I.C.	TPIC6C595	U9
1	I.C.	DS1232	U5
2	I.C.	LM348	U1,U7
2	I.C.	MAX335CNG	U2,U8
1	Jumper		JP1
3	Resistor	10K Variable	R1,R13,R25
3	Resistor	5K Variable	R7,R17,R29
1	Resistor	10K 10Pin SIP	R12
4	Resistor	10K 6Pin SIP	R8,R9,R20,R21
1	Resistor	4.7K 10Pin SIP	R24
1	Resistor	680 6Pin SIP	R31
2	Resistor	100 .25W	R4,R5
4	Resistor	620 .25W	R6,R16,R28,R30
3	Resistor	2200 .25W	R33,R34,R35 (Select Part)
9	Resistor	10K .25W	R2,R10,R11,R14,R18,R22,R23,R26,R36
4	Resistor	33K .25W	R3,R15,R19,R27
1	Switch	Dip 8 Position	SW1
6	Test Point		TP1,TP2,TP3,TP4,TP5,TP6

Chapter 12 – Remote Transceiver Weather Station Interface

In this configuration, the CAT-200B supports a transceiver and a Peet Brothers Weather Station. The transceiver is located off site and tuned to the repeater's frequency. When a weather request DTMF command is received, the CAT-200B will key the transceiver and send a weather report in a synthesized voice. A COR connection is not required.

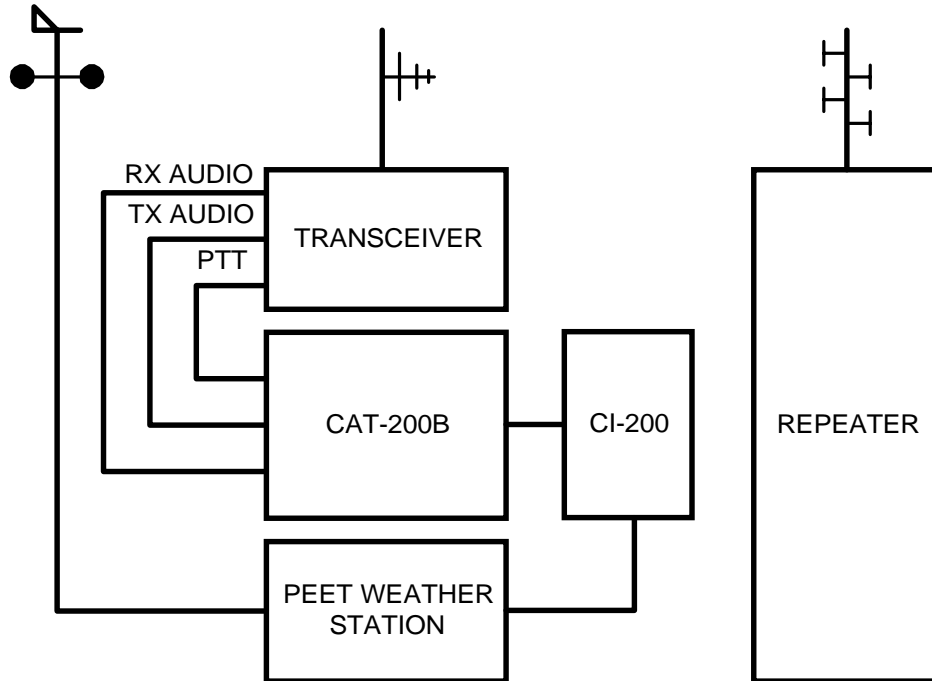

Figure 12-1

CAT-200B Transceiver Mode Set-up

Set dipswitch #5 and #7 to ON. Apply DC power to the CAT-200B. Check the power up message. The voice synthesizer will say: "CAT-200B TRANSCEIVER, VERSION 1.11, RESET SYSTEM OK, CAT-200B TRANSCEIVER." Set dipswitch #7 to OFF. Verify that Zone 1 Channel 4 is enabled. Follow the Peet Brothers Interconnect section described in Chapter 7.

Kenwood Transceiver Weather Station Interface

In this configuration the CAT-200B is connected to the microphone jack of the Kenwood TM-421 transceiver. Voltage to power the CAT-200B is derived from the +8VDC output pin #5 of the microphone jack. The equipment is located at the repeater trustee's house and tuned to the repeater output. When the proper DTMF command is received, the CAT-200B will key the transceiver and send a weather report to the input of the repeater. The CAT-200B will also work in parallel with a Peet Brothers Weather Station and a packet modem.

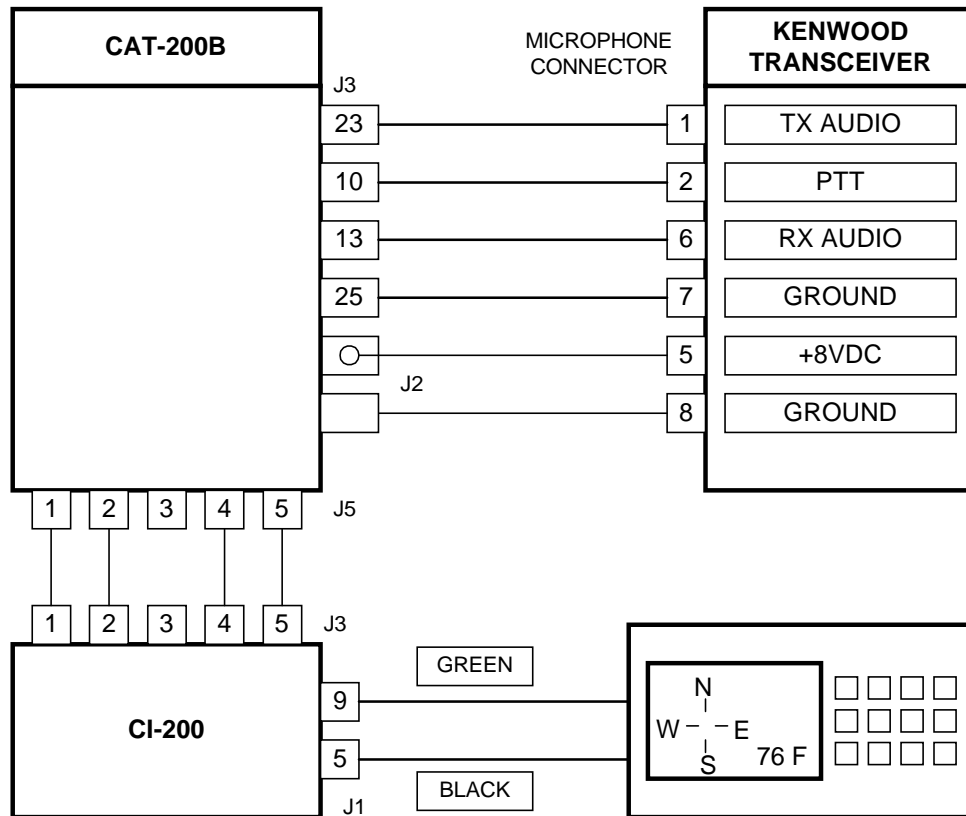

Figure 12-2

Transceiver Control Channels

In this mode the CAT-200B has two control zones for a total of sixteen control channels. These channels are controlled by DTMF commands on the transceiver's input.

Interrogation of Transceiver Control Status by Radio

Key-up and send the control operator code [100] followed by the zone number and a zero. Un-key and the voice will read back the channels that are turned on in that zone. Example: "ONE TWO FIVE ON." If all the channels are turned off, the voice will say: "CLEAR."

Changing Transceiver Control Status by Radio

To change the status of a channel, key-up and send the control operator code [100] followed by the zone number, channel number and a [1] to turn the channel ON or a [0] to turn the channel OFF. Un-key and the voice will read back the zone, channel number and control activity. The voice will say: "ONE ONE ON." or "THREE FIVE OFF." Example: With a control operator prefix of 100, turn Zone 3 Channel 6 ON.

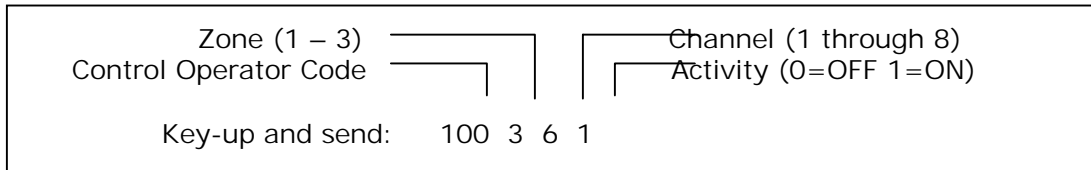

Un-key and the voice will say: "THREE SIX ON."

Zone 1

1	Transceiver Transmit	Enable*
2	Transceiver Identification	Enable*
3	DTMF Pad Test	Enable*
4	Weather Report	Enable*
5	CTCSS Encoder Switch	Enable
6	Reserved	Enable
7	Reserved	Enable
8	Reserved	Enable

Zone 3

1	Logic Input #1	Enable*
2	Logic Input #1	Enable*
3	Logic Input #1	Enable*
4	Logic Input #1	Enable*
5	Output Switch #1	Enable
6	Output Switch #2	Enable
7	Output Switch #3	Enable
8	Output Switch #4	Enable

* During initialization these control channels are set to the enable position.

Zone 1 - Transceiver Control

1. Transceiver Transmitter Enable

This is the master transceiver switch. This channel must be enabled for normal transceiver operation. The CAT-200B will continue to respond to control operator commands even when the transceiver's transmitter is disabled. This channel will automatically be enabled after a dipswitch #7 initialization reset.

2. Transceiver ID Enable

When this channel is enabled, the CAT-200B will append the voice identification any time the weather report is sent. This ID will consist of up to 15 words selected from the voice vocabulary table and is programmed with the [*3101] command. If voice message #1 is empty, the identification will be sent in CW.

3. DTMF Pad Test Enable

When this channel is enabled, a user is able to perform a test of their radio's 12 or 16-button keypad. As the numbers are being decoded, they are stored in memory. When the user stops transmitting the CAT-200B will key the transceiver and the voice synthesizer will read back all the numbers that were decoded.

4. Weather Report Enable

When this channel is enabled, the transceiver will accept the command to provide a weather report.

5. CTCSS Encoder Switch Enable

When this channel is enabled, the CTCSS Encoder Switch at J3-7 will turn ON whenever the CAT-200B responds to an input command. This switch will turn OFF only when the CAT-200B sends ID Message #1. Use this switch to gate a CTCSS encoder. During the weather report the transceiver ID will be suppressed on the output of the repeater.

6. Reserved

7. Reserved

8. Reserved

Zone 3 – Logic Inputs – Switch Outputs

1. Logic Input #1 Enable

When this channel is enabled, a logic active high input on connector J3-1 will activate voice message #3. This message is user programmable. The default message is "EMERGENCY POWER".

2. Logic Input #2 Enable

When this channel is enabled, a logic high input on connector J3-2 will activate voice message #4. This message is user programmable. The default message is "WEATHER ALERT".

3. Logic Input #3 Enable

When this channel is enabled, a logic high input on connector J3-21 will activate voice message #5. This message is user programmable. The default message is "INTRUDER ALERT".

4. Logic Input #4 Enable

When this channel is enabled, a logic high input on connector J3-22 will activate voice message #6. This message is user programmable. The default message is "HIGH TEMPERATURE".

5. Switch #1 Enable

When this channel is enabled, switch #1 is turned on. Connector J3 pin 14 will sink 50 MA to ground.

6. Switch #2 Enable

When this channel is enabled, switch #2 is turned on. Connector J3 pin 15 will sink 50 MA to ground.

7. Switch #3 Enable

When this channel is enabled, switch #3 is turned on. Connector J3 pin 19 will sink 50 MA to ground.

8. Switch #4 Enable

When this channel is enabled, switch #4 is turned on. Connector J3 pin 20 will sink 50 MA to ground.

DTMF Programming Commands (Transceiver)

ENTRY	DESCRIPTION	DEFAULT
*27	READ WEATHER STATION DATA SETTING	
*30XX	SEND VOICE MESSAGE (01-12)	
*31XX	PROGRAM VOICE MESSAGE (01-12)	
*32XX	ERASE VOICE MESSAGE (01-12)	
501	PROGRAM CONTROL OPERATOR PREFIX	100
503	PROGRAM DTMF PAD TEST PREFIX	375
504	PROGRAM WEATHER REPORT PREFIX	200
505	PROGRAM VOICE DEMONSTRATION PREFIX	700
610	PROGRAM DTMF INTERDIGIT TIMER (0.1 – 9.9 SECONDS)	1.0
*91	SEND AUDIO TEST TONE (REPEATER)	
*92	SEND AUDIO TEST TONE (LINK)	
*93	SEND AUDIO TEST TONE (REPEATER + LINK)	
*0	MANUAL EXIT OF PROGRAMMING MODE	

Figure 12-3

DTMF Inter-Digit Timer [*610*]

This timer determines the time between entries of DTMF digits that make-up a command. This timer is programmable between 0.1 and 9.9 seconds. The timer default is 1 second. When the CAT-200B is unlocked and placed in the programming mode, the DTMF inter-digit timer doubles in length. This provides more time to enter the programming commands. Once the CAT-200B is locked with the [*0] command this timer returns to the normal setting.

Chapter 13 – CI-200 Interface Board

The CI-200 Interface board provides a RS-232 port to program the CAT-200B with the ED-200 Windows Editor.

RS-232 Computer Interface

Connect your computer's COMM port to the CI-200 as described in Figure 13-1. On the CI-200 set the J2 jumper plug to the RS-232 position. On the CAT-200B check that dipswitch #6 is in the ON position.

Start the windows editor program to display the "CAT-200 Repeater Controller Editor" window. To activate the RS-232 port, set the DC power to OFF. Set dipswitch #8 to ON. Turn the DC power to ON. The CAT-200 editor program will automatically set the computer's COMM port to 4800 8,N,1.

Activation Of The RS-232 Port By Radio

To activate the RS-232 port, key-up and enter the control operator prefix code [100] followed by [97]. Un-key, the voice synthesizer will say: "CONNECT" and the transmitter will turn off.

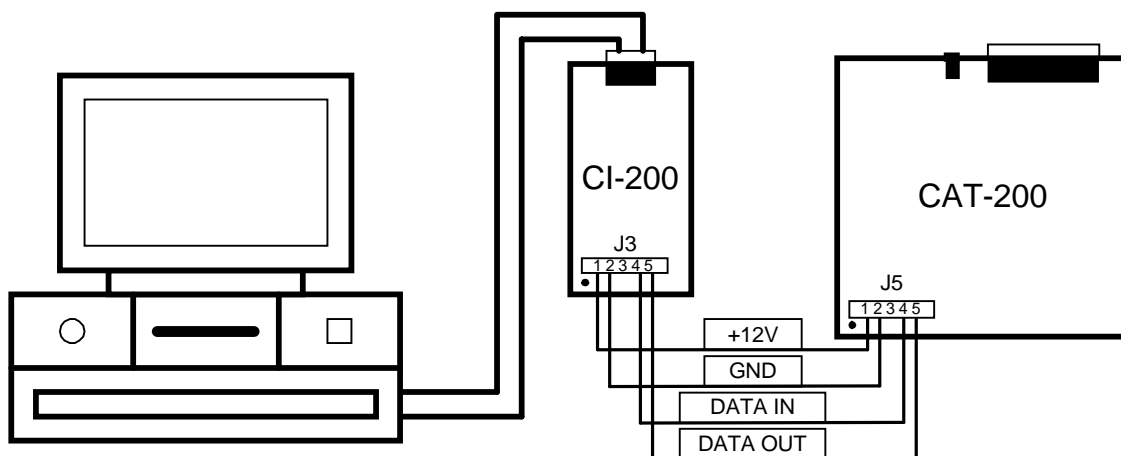

Figure 13-1

ED-200W Windows Editor

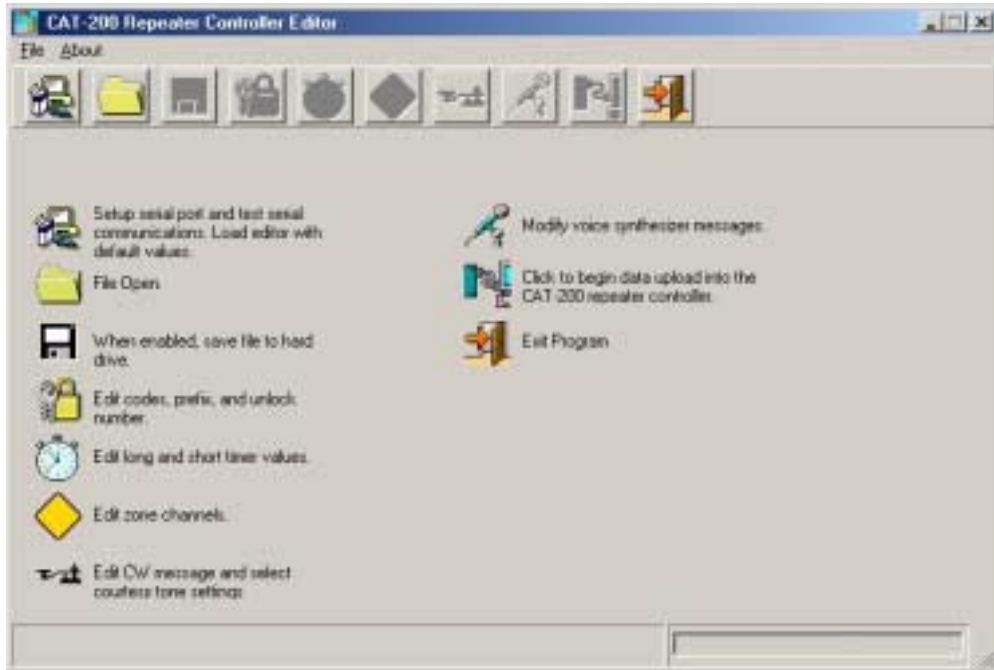

Figure 13-3

Click on **[SETUP SERIAL PORT AND TEST SERIAL COMMUNICATIONS]** button to display the “**CAT-200B Setup**” window. Click on the **[FIND SERIAL PORT]** button. Check that the program indicates the port was found and set. Click on “OK”.

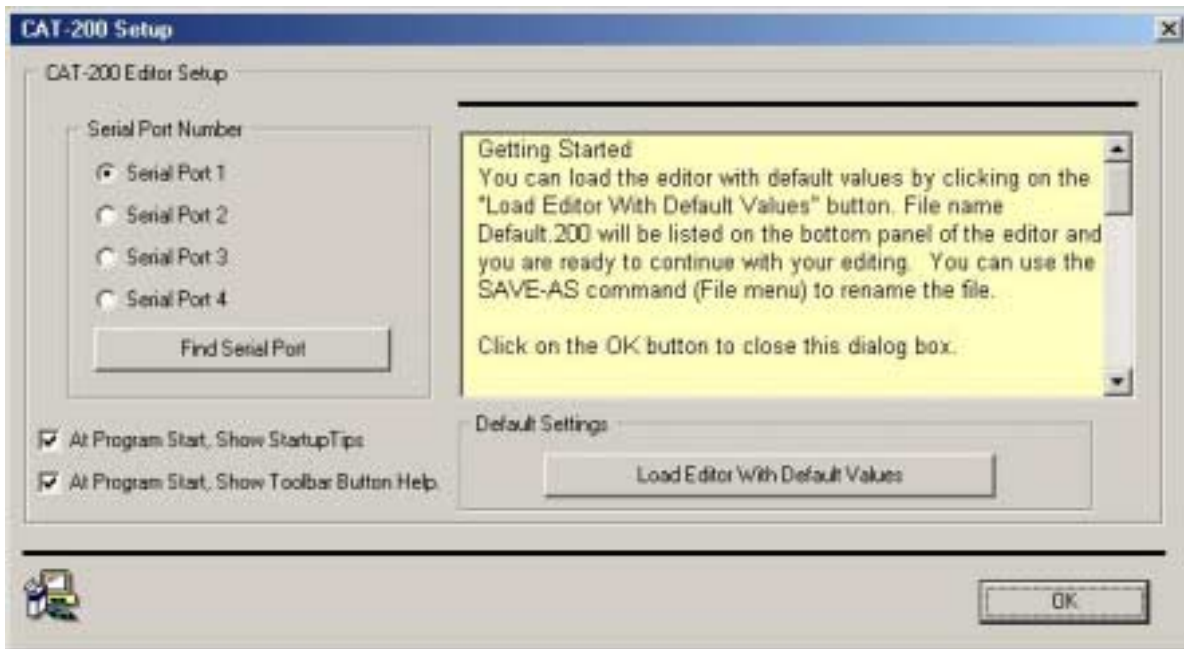

Figure 13-4

Click on the **[LOAD EDITOR WITH DEFAULT VALUES]** button.

Use the Editor to program your codes, timers, courtesy tones, zone channel settings, CW identification, and voice synthesizer messages. Save the program for future use. Click the **[DATA UPLOAD]** button to transfer the program to the CAT-200B memory.

Chapter 14 - DL-1000C Audio Delay Board

When placed in the receive audio path, the DL-1000C will eliminate the first chirp of DTMF tone during DTMF muting, and it will eliminate the squelch crash noise present on many repeater systems. A dipswitch selects delays of 50, 100, 200 or 400 milliseconds. The delayed audio is faithfully reproduced.

Installation is easy. Remove the jumper plug from the CAT-200B at J7. Connect the cable from the DL-1000C to header connector J7 to delay repeater audio. To delay remote base audio, remove the jumper plug from the CAT-200B at J6. Connect the cable from a second DL-1000C to the header connector J6.

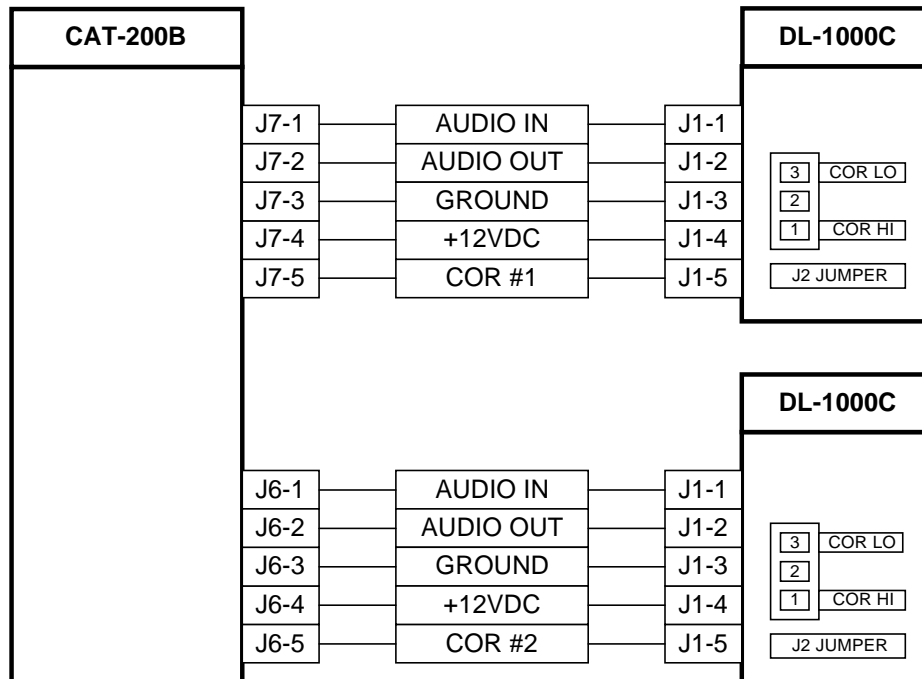

Figure 14-1

Select Delay

The amount of audio delay is determined by the setting of dipswitch SW1. The typical repeater receiver has a squelch crash noise of Approximately 40 milliseconds. The 100 millisecond setting should be sufficient to eliminate the noise in most cases. If not, increase the delay to the next setting.

MILLISECONDS	SW1	SW2	SW3	SW4
0.0	OFF	OFF	OFF	OFF
50	ON	OFF	OFF	OFF
100	ON	ON	OFF	OFF
200	ON	ON	ON	OFF
400	ON	ON	ON	ON

Figure 14-2

The DL-1000C is inserted in the receive audio path before the controller's audio switch. This audio switch is controlled by the COR logic signal. Loss of COR will cause the audio switch to open, preventing the receive audio from reaching the transmitter. The DL-1000C provides time for the switch to open before the squelch crash noise reaches the switch's input.

During DTMF muting, 40 milliseconds of the first tone will sneak through before the DTMF decoder can tell the microprocessor to open the audio switch. The DL-1000C provides the necessary delay to overcome this problem.

Discriminator Switch

The DL-1000C can be used with discriminator audio. A FET switch Q1 is included on the board. If the repeater's COR logic is connected to the J1 header, the white noise hiss will be eliminated during key-up.

If the COR logic is active high set the J2 jumper between pins 1 and 2. If the COR is active low set the J2 jumper between pins 2 and 3.

Chapter 15 - RLS-1000B Remote Link Switch

The RLS-1000B provides a method to connect up to three transceivers to the remote base port of the CAT-200B repeater controller. Transceiver selection is accomplished by grounding three control lines. Since the receiver audio and COR inputs are mixed, all three transceivers can be selected at the same time. To select a transceiver, connect the CAT-200B user function switch outputs to the control line inputs on the RLS-1000B.

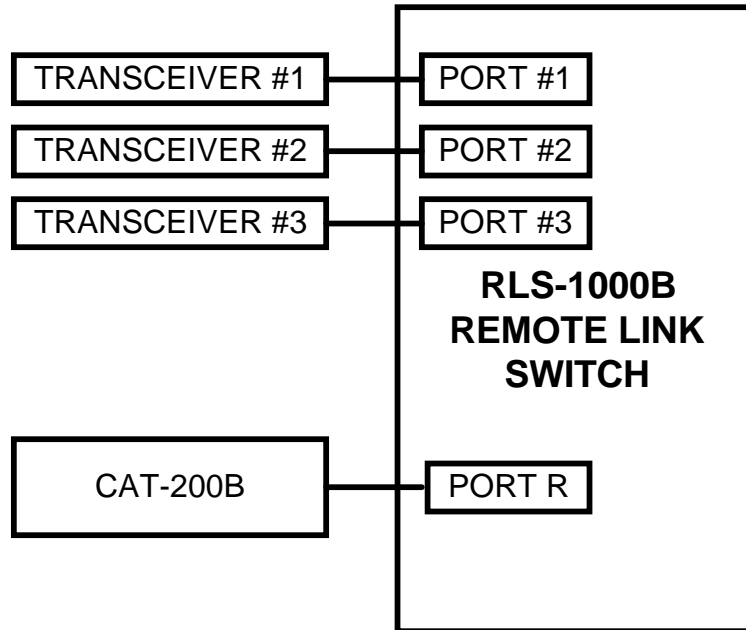

Figure 15-1

COR Output Polarity

The COR output will always be active HIGH. The COR polarity dipswitch on the CAT-200B must be set to the OFF position.

Audio Input Output

The audio input and output circuits are identical to the CAT-200B controller. Level adjustments on both the input and output amplifiers, makes it easy to compensate for varying input and output requirements. The audio input impedance is 10K ohms while the output is 600 ohms.

Receiver Audio Response

Each receiver input has a buffer amplifier with a gain of three. The frequency response is flat over a range of 300 to 3000 Hz. If discriminator audio is being used, it may be necessary to add some high frequency roll off. Space has been provided to install a capacitor across the feedback resistor on each receive audio amplifier. These locations are identified on the RLS-1000B board as C2, C11 and C16. Start with a .0047uF capacitor. Increase the value to provide more high frequency roll off or decrease the value to provide less high frequency roll off.

Dip Switch Selection

Switch #1 - Port #1 COR Polarity

This switch determines COR input logic for the RLS-1000B port #1 input. Switch #1 should be ON if the COR input is active low and OFF if the COR input is active high. For an active low COR input a pull-up resistor may be required. Install a 2200ohm .25W resistor on the RLS-1000B board at the R33 position.

Switch #2 - Port #2 COR Polarity

This switch determines COR input logic for the RLS-1000B port #2 input. Switch #2 should be ON if the COR input is active low and OFF if the COR input is active high. For an active low COR input a pull-up resistor may be required. Install a 2200ohm .25W resistor on the RLS-1000B board at the R34 position.

Switch #3 - Port #3 COR Polarity

This switch determines COR input logic for the RLS-1000B port #3 input. Switch #3 should be ON if the COR input is active low and OFF if the COR input is active high. For an active low COR input a pull-up resistor may be required. Install a 2200ohm .25W resistor on the RLS-1000B board at the R35 position.

Switch #4 - Port #1 Configuration

This switch configures port #1. If a transceiver is connected to the RLS-1000B at port #1, dipswitch #4 should be in the OFF position. If a repeater is connected to port #1, dipswitch #4 should be in the ON position.

Switch #5 - Port #2 Configuration

This switch configures port #2. If a transceiver is connected to the RLS-1000B at port #2, dipswitch #5 should be in the OFF position. If a repeater is connected to port #2, dipswitch #5 should be in the ON position.

Switch #6 - Port #3 Configuration

This switch configures port #3. If a transceiver is connected to the RLS-1000B at port #3, dipswitch #6 should be in the OFF position. If a repeater is connected to port #3, dipswitch #6 should be in the ON position.

Switch #7 - Port #1 Priority Enable

Switch #7 provides a method of assigning port #1 with priority over ports #2 and #3. If switch #7 is OFF the RLS-1000B will be configured for normal operation. Any COR input will enable the corresponding audio switch and pass the receive audio to the mixer. If switch #7 is ON port #1 will have priority. Audio switches for ports #2 and #3 will be disabled when port #1 COR is active.

Switch #8 - Port #1 CAT-300 Mode Enable

Switch #8 configures the RLS-1000B for operation with the CAT-300 in the one repeater, two-transceiver mode. This mode is not used when the RLS-1000B is connected to the CAT-200B controller.

Port R - Enable

To activate Port-R, J4 pin 12 must be grounded. With the jumper plug on J5 pins 1 and 2 Port-R is forced on. Use the CAT-200B remote base on and off commands to control the connection between the RLS-1000B and the CAT-200B.

CAT-200B - RLS-1000B Interconnect

Figure 15-2 describes how to connect three remote base transceivers to the link port of the CAT-200B controller. Control of the remote base is through user function switches one, two and three.

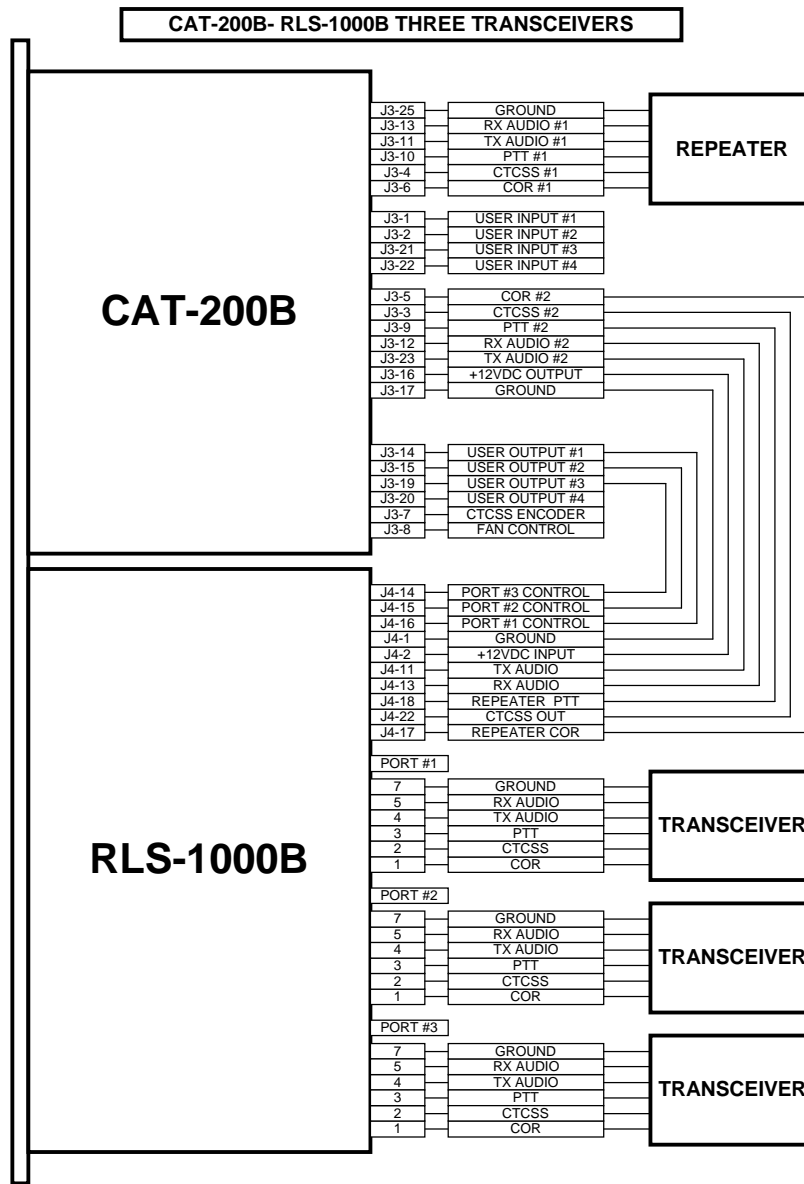

Figure 15-2